

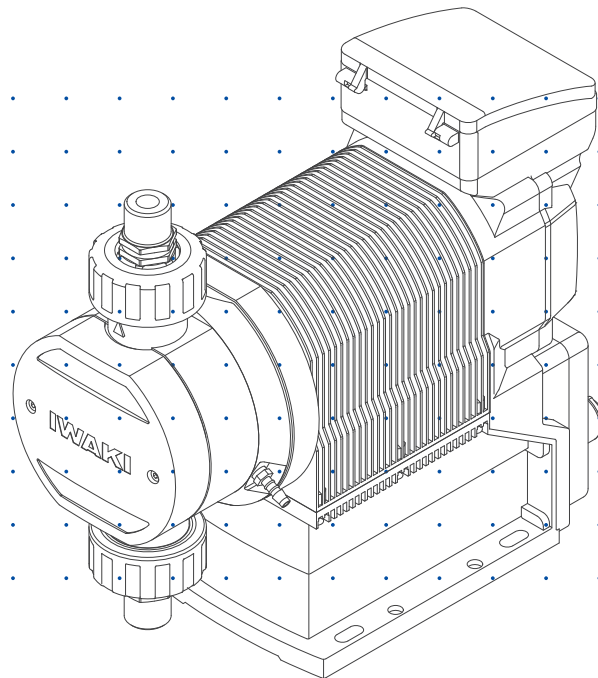

Hi-Techno Pump

IX series (North America)



Instruction manual

Thank you for choosing our product.

 Please read through this instruction manual before use.



This instruction manual describes important precautions and instructions for the product. Always keep it on hand for quick reference.

Order confirmation

Open the package and check that the product conforms to your order. If any problem or inconsistency is found, immediately contact your distributor.

a. Check if the delivery is correct.

Check the nameplate to see if the information such as model codes, discharge capacity and discharge pressure are as ordered.

Hi-Techno Pump			
Model			
Capacity	L/H GPH	Max. Pressure	MPa PSI
Frequency	Hz	Voltage	VAC
Max. liquid temp.	°C	Power Consumption	W
Current	A	Year :	
MFG.No.			
Conforms to UL Std.778 Certified to CAN/CSA Std.C22.2 No.108		Acceptable for indoor use only Enclosure type 2 Utilisation intérieure uniquement Boîtier de type 2 Nonsubmersible Pump	
IWAKI CO.,LTD. MADE IN JAPAN			

● To reduce risk of electric shock, grounding-type receptacle must be used.
Afin de réduire le risque de choc électrique, uniquement raccorder à terre correctement.

● Risk of electric shock in swimming pool or near water.
Risque de choc électrique si utilisé dans une piscine ou à proximité de l'eau.

● This pump has been tested and approved for use in swimming pools.
Cette pompe a été testée et approuvée pour utilisation dans les piscines.

b. Check if the delivery is damaged or deformed.

Check for transit damage and loose bolts.

Contents

Order confirmation	2
<i>Safety instructions</i>	6
Warning	7
Caution	8
Precautions for use	10
<i>Overview</i>	12
Introduction	12
Pump structure & Operating principle	12
Features	13
Operational function	13
Manual mode	13
EXT mode	14
Analogue control	14
Pulse control	14
Batch control	15
Interval batch control.....	15
AUX function	16
Priming function	16
STOP function.....	17
Pre-STOP function.....	17
Protective functions.....	18
Interlock function.....	18
Diaphragm rupture detection	18
Pressure overload detection	18
Output function.....	19
Other functions.....	19
Suction speed setting.....	19
Diaphragm position adjustment	19
Anti chattering programming.....	19
Flow unit setting	19
Language setting	19
Keypad lock.....	19
Default.....	19
Part names	20
Pump	20
Operational panel.....	21
Basic displays & Pump states	22
Identification codes	23
Pump	23

<i>Installation</i>	<i>24</i>
Pump mounting	24
Pipework	25
Piping layout	25
Drain port (Vent hole)	26
Wiring	27
End terminals	27
Power voltage/Earthing	28
Signal wire connection	29
Input signal	30
STOP signal	30
AUX signal	31
Output signal	31
<i>Operation</i>	<i>32</i>
Before operation	32
Points to be checked	32
Retightening of pump head fixing bolts	32
Commissioning	33
Before a long period of stoppage (One month or more)	33
Perform a calibration	34
Calibration process	35
Operation programming	37
Programming flow	38
Menu screen	39
EXT mode selection	40
Calibration	42
Signal input setting	42
Alarm 1 setting	44
Alarm 2 setting	45
Data logging	46
Programming of other functions	47
Operation	50
Manual operation	50
EXT operation	50
AUX function	51
Priming function	51
Keypad lock	52
Keypad lock activation	52
Keypad lock release	52
Emergency stop	52

Troubleshooting **54**

 Pump 54

Error messages **55**

Inspection **55**

 Daily inspection 55

 Periodic inspection 55

Wear part replacement **56**

 Wear part list 56

 Before replacement 58

 Valve set replacement 58

 Diaphragm replacement 59

Exploded view **63**

 Pump head, Drive unit & Control unit 63

 Pump head 64

 IX-C150 TC N 64

 IX-C150 TC FA 65

 IX-C150 S6 N 66

 IX-C150 S6 FA 67

 IX-C060 TC N 68

 IX-C060 TC FA 69

 IX-C060 S6 N 70

 IX-C060 S6 FA 71

Specifications/Outer dimensions **72**

 Specifications 72

 Pump 72

 Power cable 72

 Body colour 72

 Control unit 73

 Outer dimensions 74

 IX-C060/-C150 TC/TE N-TB 74

 IX-C060/-C150 TC/TE FA-TB 75

 IX-C060/-C150 TC/TE N-RF 76

 IX-C060/-C150 TC/TE FA-RF 77

 IX-C060/-C150 S6 N-TB 78

 IX-C060/-C150 S6 FA-TB 79

 IX-C060/-C150 S6 N-RF 80

 IX-C060/-C150 S6 FA-RF 81

Safety instructions

Read through this section before use. This section describes important information for you to prevent personal injury or property damage.

■ Symbols

In this instruction manual, the degree of risk caused by incorrect use noted with the following symbols. Please pay attention to the information associated with the symbols.



WARNING

Indicates mishandling could lead to a fatal or serious injury accident.



CAUTION

Indicates mishandling could lead to personal injury or property damage.

A symbol accompanies each precaution, suggesting the use of "Caution", "Prohibited actions" and specific "Requirement".

Caution marks



Caution



Electrical shock

Prohibition mark



Prohibition



Do not remodel

Requirement mark



Requirement



Wear protectors



Earthing

Export restrictions

Technical information contained in this instruction manual might be treated as controlled technology in your countries, due to agreements in international regime for export control.

Please be reminded that export license/permission could be required when this manual is provided, due to export control regulations of your country.

! WARNING

Electrical shock

Turn off power before work

Risk of electrical shock. Be sure to turn off power to stop the pump and related devices before work.

Couper l'alimentation électrique de la pompe avant d'intervenir

Risque de décharges électriques. Assurez vous d'avoir couper l'alimentation électrique de la pompe et de tout dispositif connexe avant toute intervention.



Requirement

Stop operation

On sensing any abnormality or dangerous sign, suspend operation immediately and inspect/solve problems.

Arrêter le fonctionnement

Si vous détectez une anomalie ou des signes suspects, interrompez immédiatement les opérations et contrôlez/résolvez les problèmes.



Prohibition

Do not use the pump in anything other than a specified purpose

The use of the pump in any purpose other than those clearly specified may result in failure or injury. Use this product in a specified condition only.

Ne pas utiliser la pompe pour autres chose que les applications prévues

Toute utilisation non conforme peut entraîner un accident ou endommager le dispositif. Utilisez la pompe dans les conditions décrites.



Do not remodel

Do not modify the pump

Remodelling the pump carries a high degree of risk. We are not responsible for any failure or injury results from remodelling.

Ne pas modifier la pompe

Modifier une pompe présente un haut risque. Nous ne pourrions être tenus responsables d'un accident ou de dégâts survenus à la suite de la modification du dispositif.



Wear protectors

Wear protective clothing

Always wear protective clothing such as an eye protection, chemical resistant gloves, a mask and a work cap during dismantlement, assembly or maintenance work.

Porter un équipement de protection

Toujours porter des vêtements de protection comme des protections pour les yeux, des gants résistants aux produits chimiques, un masque et une blouse pendant les travaux de démontage, montage et les travaux de maintenance.



Prohibition

Do not damage the power cable

Do not pull or knot the power cable or place a heavy stuff on it. Damage to the power cable could lead to a fire or electrical shock when it is bared or disconnected.

N'endommagez pas le câble électrique

Ne tirez pas sur le câble, ne faites pas des nœuds avec le câble ou protégez-le. Un câble électrique endommagé peut provoquer un incendie ou un choc électrique si il est dénudé ou déconnecté.



Prohibition

Do not use the pump in a flammable atmosphere

Do not place dangerous or flammable goods near the pump for your safety.

Ne pas utiliser la pompe dans une atmosphère inflammable

Pour votre sécurité, ne pas placer de biens dangereux ou inflammable à côté de la pompe.



Risk of electric shock

This pump is supplied with a grounding conductor and grounding-type attachment plug. To reduce the risk of electric shock, be certain that it is connected only to a properly grounded, grounding-type receptacle.

Risque de décharges électriques

Veillez à ne pas faire fonctionner la pompe sans avoir au préalable prévu une mise à la terre. Celle-ci permettra d'éviter d'éventuelles décharges électriques. Vérifiez que le câble de mise à la terre est bien branché.

⚠ CAUTION



Requirement

A qualified operator only

The pump must be handled or operated by a qualified person with a full understanding of the pump. Any person who is not familiar with this product should not take part in operation or management.

Uniquement du personnel qualifié

La pompe doit être manipulée uniquement par du personnel qualifié connaissant parfaitement son fonctionnement. Les personnes ne connaissant pas le produit ne doivent pas intervenir.



Prohibition

Use a specified power only

Do not apply any power other than the one specified on the nameplate. Otherwise, failure or fire may result. Also, be sure to earth the pump.

Utilisez uniquement la tension spécifiée

Ne pas utiliser une tension autre que celle indiquée sur la plaque du constructeur. Autrement une panne ou un incendie peut survenir. Assurez vous aussi de la mise à la terre de la pompe.



Prohibition

Do not wet electric parts or wiring

Risk of fire or electrical shock. Install the pump free from liquid spill.

Ne pas mouiller l'installation ou les parties électriques

Risque d'incendie ou de décharge électrique, Installez la pompe près d'un écoulement de liquide.



Caution

Ventilation

Poisoning may result when handling a toxic or odorous liquid. Keep good ventilation in your operating site.

Ventilation

Manipuler un produit toxique ou odorant peut provoquer une intoxication. Prévoyez une ventilation suffisante à l'endroit de la manipulation.



Prohibition

Do not install or store the pump in the following places where...

- Under a flammable atmosphere or in a dusty/humid place.
- Ambient temperature is beyond 0-50 degrees Celsius.
- Under direct sunlight or wind & rain.

Ne pas installer ou stocker la pompe dans les endroits suivants:

- Dans une atmosphère inflammable ou un endroit poussiéreux/humide.
- Dans un local où la température n'est pas comprise entre 0°C et 50°C.
- Directement en contact aux rayons du soleil, au vent et à la pluie.



Caution

This pump has been evaluated for use with water only.
Cette pompe a été testée uniquement avec de l'eau.



Requirement

Countermeasure against efflux

Take a protective measurement against an accidental chemical overflow results from pump or piping breakage.

Précautions contre les fuites

Prévoir des mesures de protection en cas de déversement accidentel de produits chimiques à la suite d'une défaillance inattendue de la pompe ou de la tuyauterie.



Prohibition

Do not use the pump in a water place

The pump is not totally waterproof. The use of the pump in water or high humidity could lead to electrical shock or short circuit.

Ne pas utiliser cette pompe dans un endroit avec de l'eau

La pompe n'est pas complètement étanche. L'utilisation de la pompe dans des lieux à forte humidité peut entraîner une décharge électrique ou un court circuit.



Earthing

Earthing

Risk of electrical shock. Always earth the pump.

Mise à la terre

Risque de décharges électriques. Toujours mettre la pompe à la terre



Electrical shock

Install an earth leakage breaker

An electrical failure of the pump may adversely affect related devices. Purchase and install an earth leakage breaker separately.

Installez un différentiel

Une défaillance électrique accidentel de la pompe peut affecter l'installation électrique. Afin d'éviter d'éventuelles décharges électriques, achetez (vendu séparément) et installez un différentiel.



Requirement

Wear part replacement

Follow instructions in this manual for wear part replacement. Do not dismantle the pump beyond the extent of the instructions.

Remplacement des parties usées

Suivre les instructions dans ce manuel pour le remplacement des parties usées. Ne pas démonter la pompe au-delà de la mesure des instructions.



Prohibition

Do not use a damaged pump

Using a damaged pump could lead to an electric leak or shock.

Ne pas utiliser une pompe endommagée

Utiliser un pompe endommagé peut conduire à une décharge ou un choc électrique.



Requirement

Disposal of a used pump

Dispose of any used or damaged pump in accordance with relevant regulations. Consult a licensed industrial waste products disposing company.

Elimination des pompes usées

Elle doit se faire en conformité avec les règles locales en vigueur (consultez une entreprise certifiée et spécialisée).



Caution

Tighten the pump head

Liquid may leak if eight M8 pump head fixing bolts have been loosened. Remove a bolt cover and tighten the bolts diagonally and uniformly by 12N•m (IX-C150) or 3.5N•m (IX-C060) before initial operation or at periodic intervals.

Resserrez le corps de pompe

Il pourrait y avoir une fuite de liquide si les 8 boulons M8 du corps de pompe ne sont pas bien serrés. Enlevez le cache boulon et resserrez les boulons diagonalement et uniformément (12N•m: IX-C150, 3.5N•m: IX-C060) avant la première utilisation et à intervalles réguliers.

Precautions for use

- Electrical work should be performed by a qualified operator. Otherwise, personal injury or property damage accident may result.

Les travaux électriques doivent être réalisés par du personnel qualifié. Autrement des dégâts matériel ou personnel peuvent survenir accidentellement.



- Do not install the pump in the following places where...
 - Under a flammable atmosphere or in a dusty/humid place.
 - Under direct sunlight or wind & rain.
 - Ambient temperature is beyond 0-50 degrees Celsius.

Ne pas installer ou stocker la pompe dans les endroits suivants:

- Dans une atmosphère inflammable ou un endroit poussiéreux/humide.
- Dans un local où la température n'est pas comprise entre 0°C et 50°C.
- Directement en contact aux rayons du soleil, au vent et à la pluie.

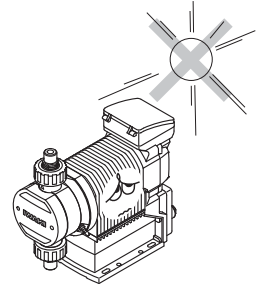

- Select a level location where is free from vibration and liquid can't stay. Anchor the pump with four M8 bolts so as not to vibrate. If the pump is installed at a tilt, the flow may reduce.

Sélectionnez un endroit sans vibration afin que le liquide reste en place. Fixer la pompe avec des vis M8 pour qu'elle ne vibre pas. Si la pompe est installée dans une pente, le flux peut être réduit.

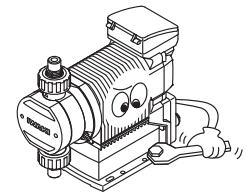

- When two or more pumps are installed, the pumps may start to vibrate significantly, resulting in poor performance or failure of internal electrical devices. Select a concrete foundation and fasten anchor bolts tightly to prevent the pumps from vibrating during operation.

À partir de deux pompes installées, il se pourrait que les pompes commencent à vibrer significativement. Ce qui aurait pour effets de mauvaises performances, des pannes du dispositif électrique interne. Choisissez un endroit solide et fixez les boulons fermement pour empêcher la pompe de vibrer pendant l'opération.



- There should be sufficient space around the pump to enable efficient and easy maintenance.

Il doit y avoir un espace suffisant autour de la pompe afin d'effectuer une maintenance facile et efficace.



- Install the pump as close to a supply tank as possible.
Installez la pompe près du réservoir.



- Install the pump in a cool and dark place when handling liquids that readily generate gas bubbles such as sodium hypochlorite or hydrazine solution. Flooded suction application is strongly recommended when mounting the pump below the level of liquid in the supply tank.

Installer la pompe dans un endroit frais et sombre quand le liquide utilisé génère des bulles de gaz comme l'hypochlorite de sodium ou une solution d'hydrazine. Un montage sans fuite à l'aspiration est fortement recommandé si on utilise la pompe avec un réservoir.



- The suction line bore should be wider than the inlet bore of the pump.
La ligne d'aspiration doit être plus large que l'entrée de la pompe.



- Keep the pump free from any effect of piping expansion and contraction due to thermal stress.

La pompe ne doit pas être soumise à des effets éventuels de dilation ou de contraction du pipe dus à un stress thermique.



Caution

- Overload protection will stop operation when the discharge pressure has risen to 1.5 to 2 times higher than the maximum. Install a relief valve to depressurize a discharge line if the pressure resistance of discharge line will not bear the possible highest pressure.

Un dispositif de protection en cas de surcharge doit pouvoir arrêter le dosage quand la pression au refoulement s'élève de 1,5 à 2 fois le maximum admis. Installez une vanne de sécurité pour relâcher la pression de la ligne de refoulement si la ligne de refoulement ne peut pas supporter de haute pression.



Caution

- Be careful not to drop the pump onto the floor. A strong impact may reduce pump performance. Do not use a pump which has once damaged. Otherwise an electrical leak or shock may result.

Faire attention de ne pas faire tomber la pompe par terre. Un choc important peut réduire ses performances. Ne pas utiliser une pompe qui a été endommagée. Un décharge ou un choc électrique pourrait se produire.

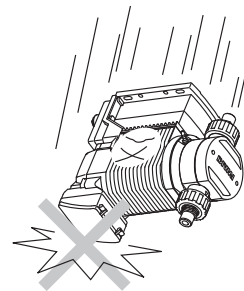

- The pump is water-/dust-proof of IP65, but is not totally waterproof. Do not have the pump wet with the liquid handled or rainwater.

La pompe est IP65 (protection vis à vis de l'eau et de la poussière) mais pas complètement résistante à l'eau. Ne mouillez pas la pompe avec le liquide pompé ou avec de l'eau de pluie.



Caution

- Never wet the pump head, control unit and drive unit. Otherwise, Failure or an accident may result. Immediately wipe off liquid if the pump has got wet.

Ne jamais mouiller la tête de pompe, l'unité de contrôle ou le panneau de commande. Autrement une défaillance ou un accident peut se produire. Enlever immédiatement le liquide si la pompe a été mouillée.



Caution

- Do not close the discharge line during operation. Otherwise, liquid may leak or piping may break. Install a relief valve to be sure to prevent a leak or a piping break.

Ne fermez pas la ligne au refoulement pendant le fonctionnement sinon, le fluide pourrait fuir ou le pipe se casser. Installez une vanne de sécurité pour être certain de prévenir toute fuite ou toute rupture du tuyau.



Requirement

- Release the pressure from the discharge line before dismantling the pump or removing piping. Otherwise, chemical liquid gushes out.

Evacuer la pression au refoulement avant de démonter la pompe ou de changer le pipe sous peine de projection de liquides chimiques.



Requirement

- Be careful not to come in contact with residual liquid.

Faite attention de ne pas être en contact avec le liquide résiduel.



Caution

- Do not clean the pump or nameplate with a solvent such as benzene and thinner. This may discolour the pump or erase printing. Use a dry cloth or a wet cloth with water or neutral detergent.

Ne pas nettoyer la pompe ou la plaque constructeur avec un solvant comme le benzène ou le thinner. Cela risque de décolorer la pompe ou effacer les inscriptions, Utiliser un chiffon sec ou humide avec de l'eau ou un détergent neutre.



Overview

The information such as characteristics, features and part names are described in this section.

Introduction

Pump structure & Operating principle

The IX series is a diaphragm pump with a BLDC motor and features a high turndown ratio & automatic controls.

Principle of operation

In the IX series design, a BLDC motor rotation controls a flow rate.

Motor rotation is transmitted to an eccentric cam through a reduction gear and then converted to reciprocating motion. Volumetric change occurs in the pump head as a diaphragm moves back and forth and pumps liquid along with valve action. A flow rate changes with a discharge speed while a suction speed is always the same at any flow rate.

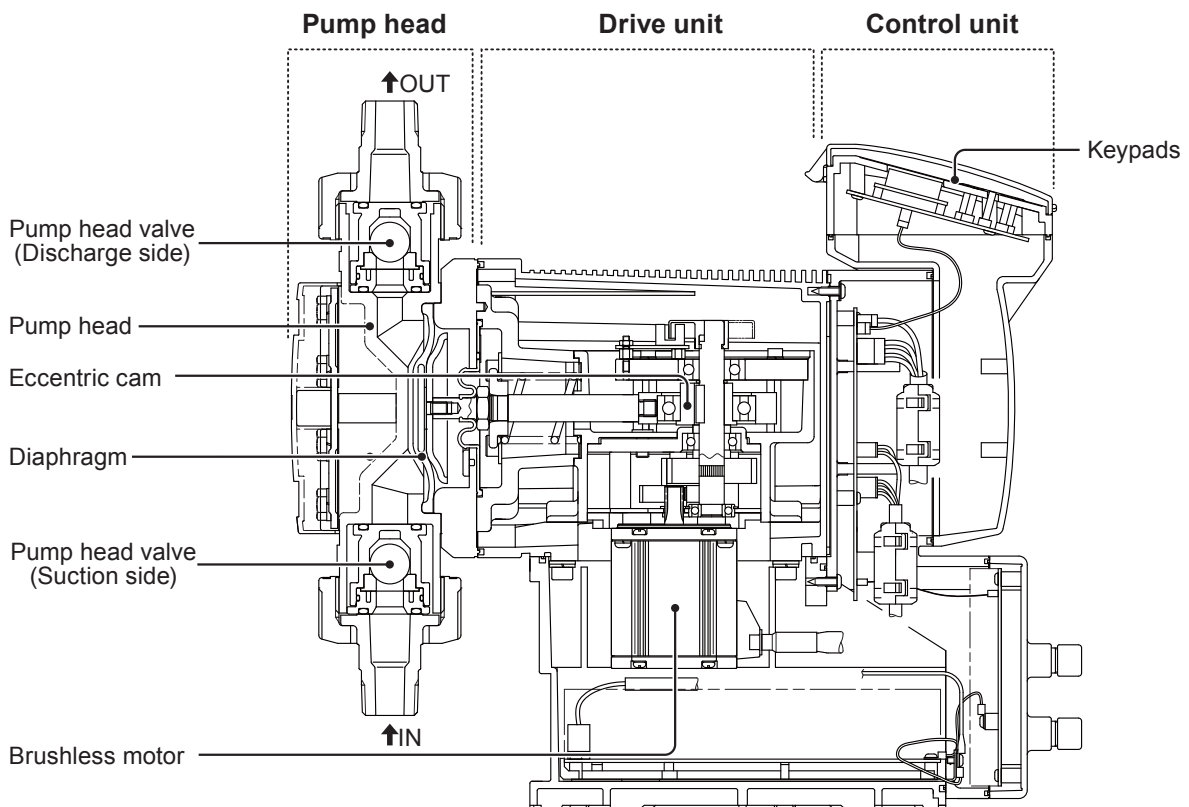

Features

- **High turndown ratio**

Use of a BLDC control motor enables accurate control with a wide turndown ratio.

- **High repeatability**

Highly-efficient valve design and accurate discharge-/suction-speed controls assure the high repeatability of chemical dosing ($\pm 1\%$).

- **Energy-saving design**

Use of helical gears and an assist spring reduces power consumption by 70% compared to our existing metering pump designs (spring back).

- **Automatic control**

The IX can automatically run along with analogue-, pulse-, batch- or interval batch-operation programming.

- **Multivoltage operation**

The IX series can be used in all countries thanks to the universal power voltage (100-240VAC).

- **Safety design**

A diaphragm rupture detection ensures user safety and a pressure overload detection protects the pump and pipework from an accidental discharge line pressure rise.

- **Ingress protection rating of IP65**

Operational function

Manual mode

Run/stop the pump by key operation. A flow rate can be changed by the up and the down keys at any time during operation or stop. The operation LED lights in green colour during operation. See page 50 for detail.

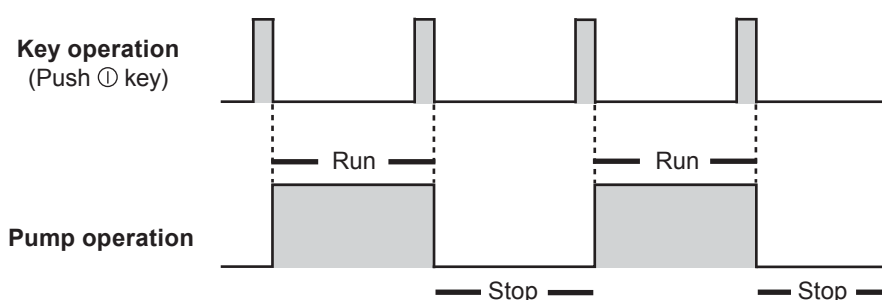

EXT mode

■ Analogue control (See page 40 & 50)

Select a proportional control pattern. 4 - 20mA, 20 - 4mA, 0 - 20mA and 20 - 0mA are available.

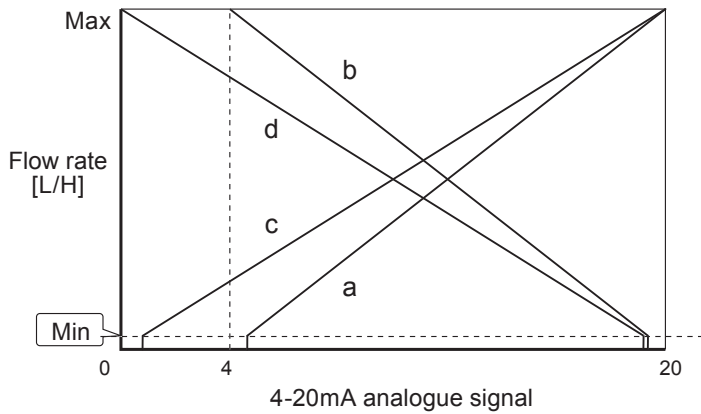

The left graph is in the following patterns.

- a. 4 - 20mA
- b. 20 - 4mA
- c. 0 - 20mA
- d. 20 - 0mA

*A flow rate falls to 0mL/H if the pump runs beneath the minimum rate. The pump does not run over the maximum flow rate at any current value.

Example of use: pH control in a water treatment system

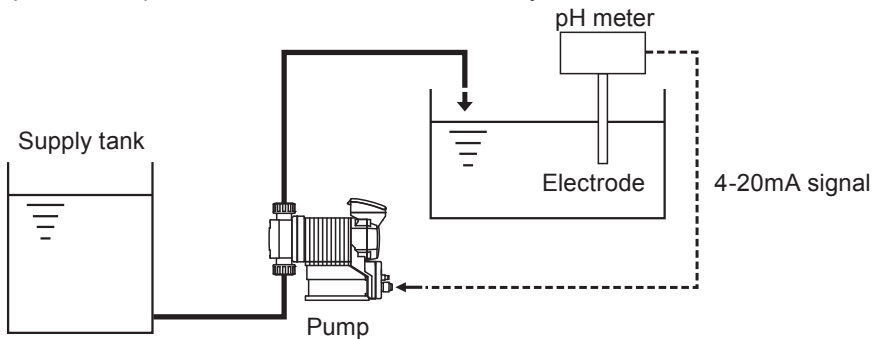

■ Pulse control (See page 41 & 50)

A flow rate is automatically controlled by flow volume (ml) per pulse and a pulse signal frequency from a flow meter.

*It takes about 10 pulses for the IX to catch up with the change of the frequency.

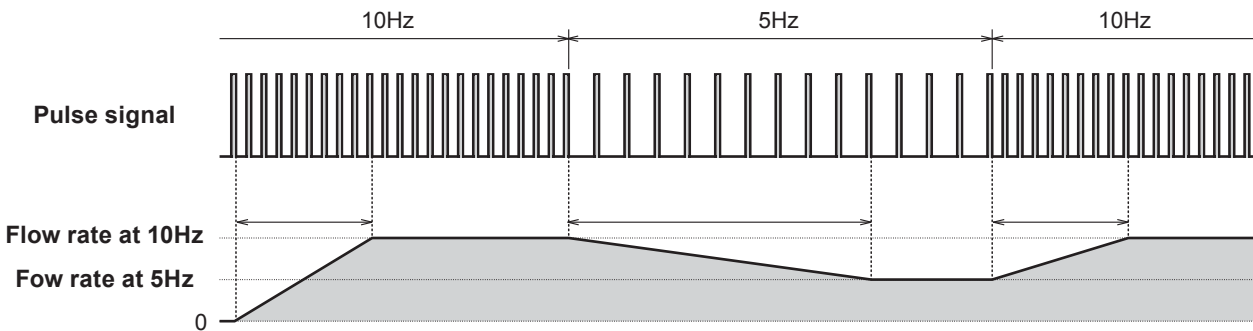

Example of use: Chemical dosing in a sewage treatment system

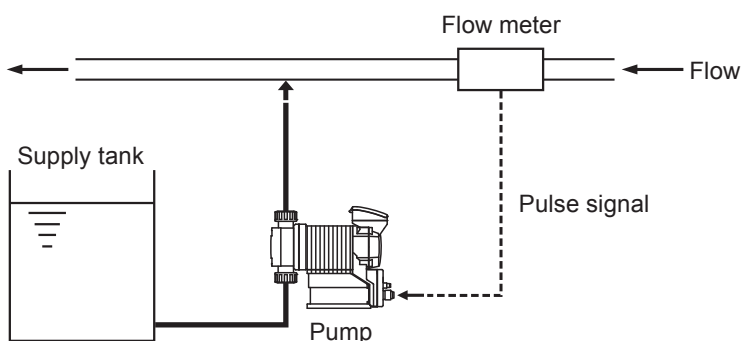

■ Batch control (See page 41 & 50)

The IX discharges a programmed flow volume per pulse. When the pump receives pulse signals in dosing, the next dosing is sequentially processed. The signals are stored up to 65535.

*The pump runs to meet the programmed flow rate in the manual mode (MAN speed). Set it to the max in that mode before starting batch control.

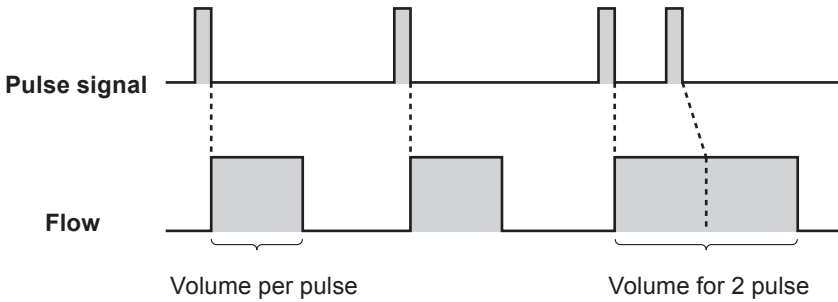

Example of use: Chemical dosing in a production line system

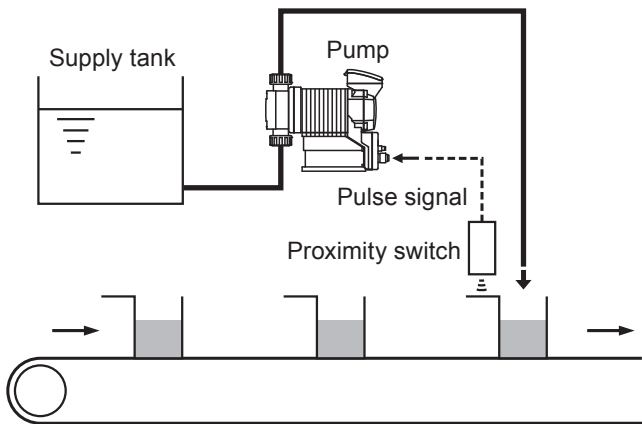

■ Interval batch control (See page 41 & 50)

To make an interval batch control, set a date and time interval and a flow rate. The IX discharges the programmed flow rate at a set interval. In the diagram below, the interval is set to 1 hour.

*The pump runs to meet the programmed flow rate in the manual mode (MAN speed).

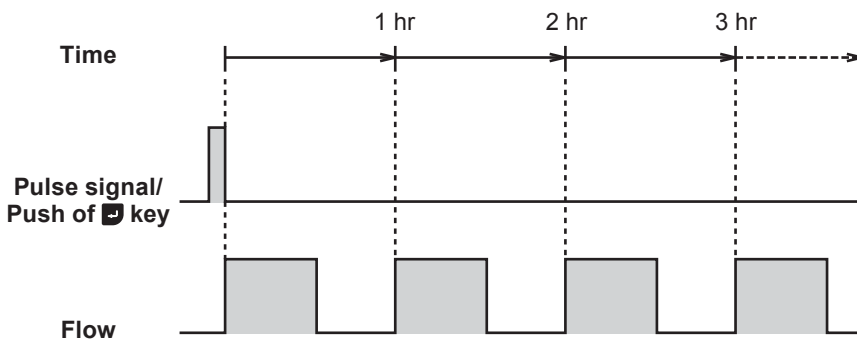

Example of use: Water transfer for a sprinkler system

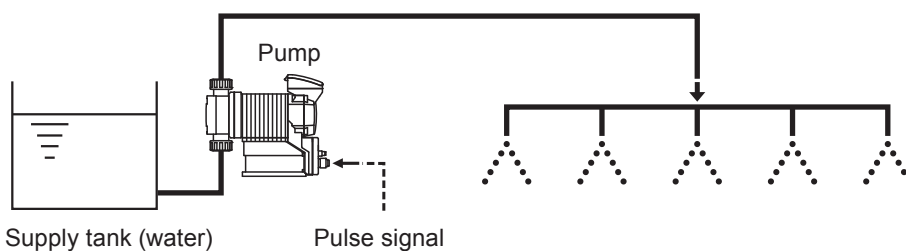

■ AUX function (See page 48)

The pump runs at an AUX speed while receiving the external signal via the AUX terminal.

*This function works only when the pump is running in either MAN or EXT mode (see page 38.). The pump returns to a MAN speed once the AUX signal stops.

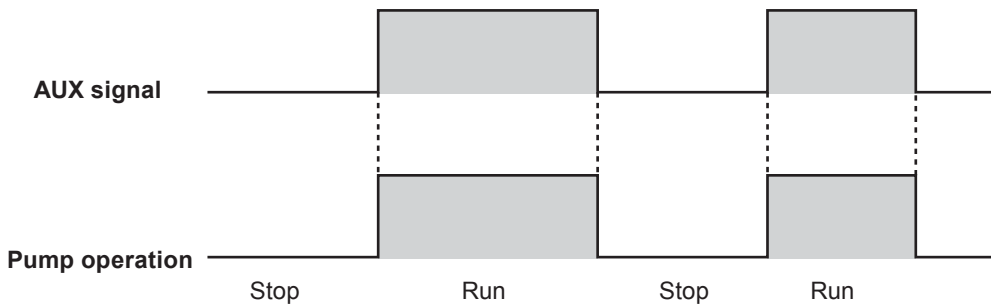

■ Priming function (See page 51)

The pump runs at the maximum stroke rate while both the UP and DOWN keys are pressed. Use this function for priming or degassing. Release both the keys to stop the pump.

*This function is available at any time except when the pump is in the MAN/EXT selection or menu selection (See page 38.).

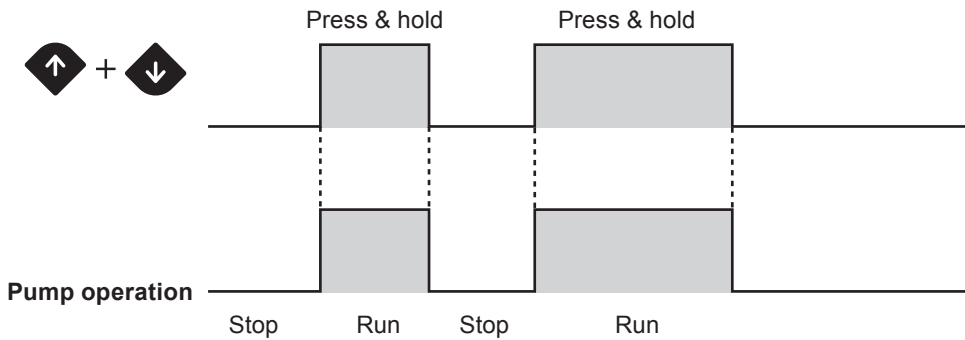

■ **STOP function (See page 42)**

The start/stop of operation can be controlled by a signal from a level sensor. See page 30 "STOP signal" for wiring diagram.

Example of use: Liquid level monitoring

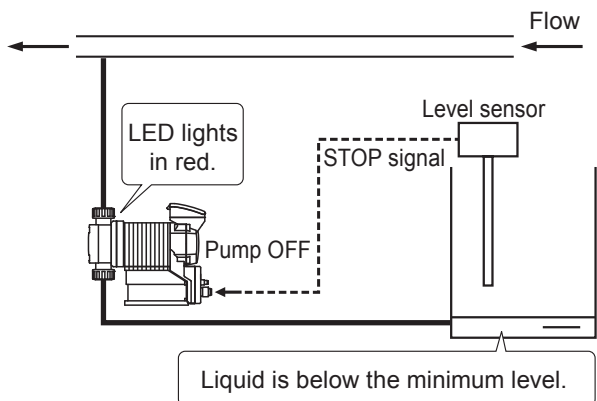

The pump stops when liquid has fallen below the minimum level.

■ **Pre-STOP function (See page 42 & 43)**

Liquid level in a supply tank can be monitored by a signal from a level sensor. See page 30 for wiring diagram. The operation LED changes from green to orange colour when the pump is receiving the Pre-STOP signal from a level sensor in operation. See page 30 "STOP signal" for wiring diagram.

Example of use: Liquid level monitoring

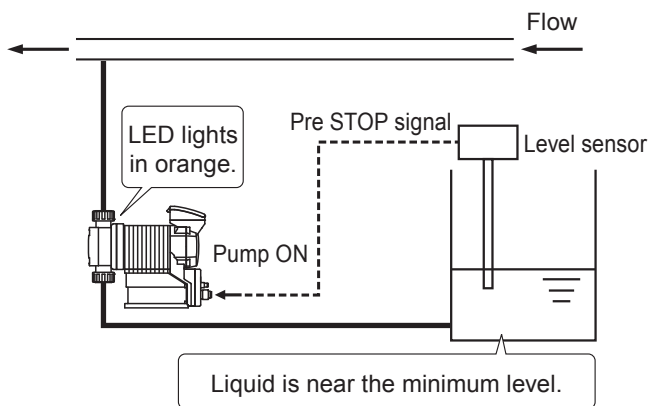

The operation LED lights in orange colour to inform a user that liquid comes close to the minimum level in a supply tank.

Protective functions

■ Interlock function (See page 42 & 43)

The start/stop of operation can be controlled by a signal from an external device. See page 30 "STOP signal" for wiring diagram. Interlock function works in the same way as the STOP function but uses a preference circuit. Use this function for emergency stop.

■ Diaphragm rupture detection (See page 42 & 43)

The pump stops right after a built-in sensor detects a leak in the compartment at the back of the diaphragm. In this state the operation LED lights in red colour. Replace a broken diaphragm as necessary. See page 59 for diaphragm replacement. To release this error condition, push the start/stop key (or the ESC key under Profibus control.).

NOTE

This capacitance sensor does not work properly if liquid conductivity is 1mS/m or below. Before sending pure water, oil or any other low-conductivity liquid, check its conductivity to see if it meets the minimum level. Do not use this function when it is 1mS/m or below. Instead, check the diaphragm for damage and replace it on finding a leak from the drain port. Otherwise, the pump may fail.

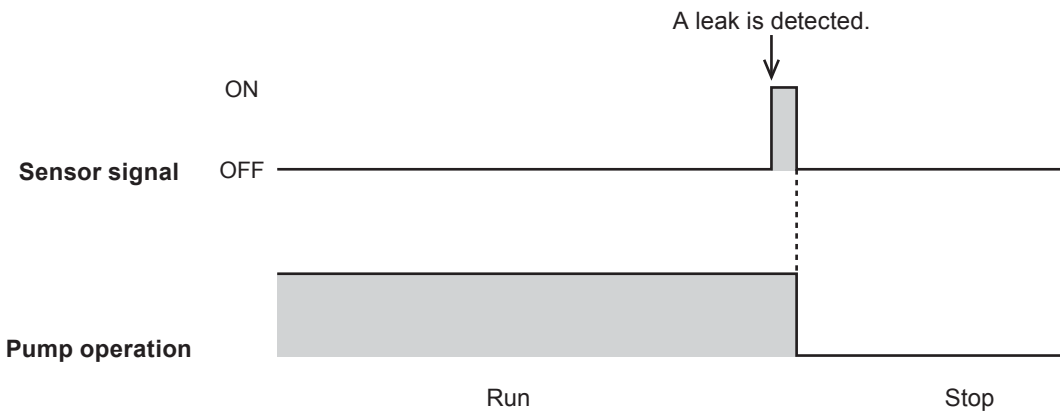

■ Pressure overload detection

The pump stops right after a built-in sensor detects 1.3-2.0 times higher discharge pressure than the maximum level. In this state the operation LED flashes in red colour. The pump resumes operation 30 seconds after the stoppage. If pressure overload has recurred 5 times consecutively, the pump will not resume operation any more and will keep still. Push the start/stop key to release this state.

NOTE

A detection level varies with operating conditions and a piping layout within the above pressure range. Set up a relief valve if the pressure resistance of other related devices is lower than that range.

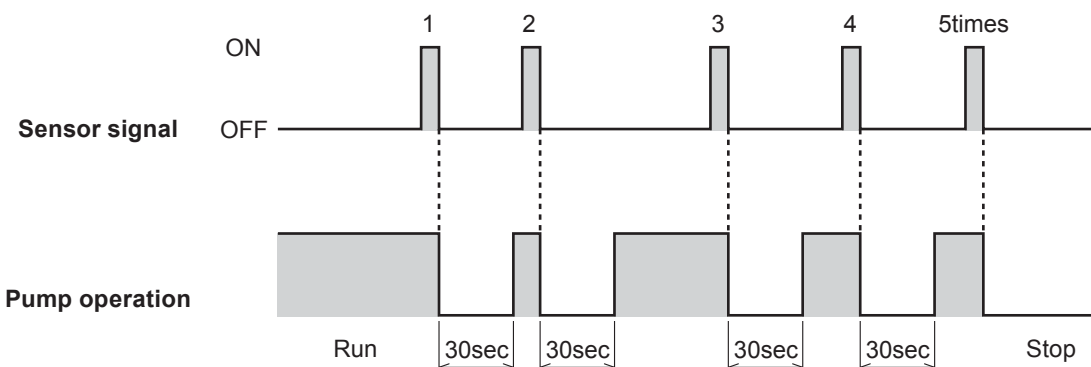

■ Output function (See page 44 & 45)

Set the STOP, Pre-STOP, Interlock, Diaphragm rupture detection and Pressure overload detection outputs to the Alarm1 and Alarm2. See page 31 "Output signal" for wiring diagram.

Alarm1: Mechanical relay output

(No voltage contact 1a×1 250VAC 3A Resistive load)

Alarm2: PhotoMOS relay output

(No voltage contact 1a×1 24VAC/DC 0.1A Resistive load)

Other functions

■ Suction speed setting (See page 47)

Suction speed is adjustable by 4 levels depending on liquid property. Reduce suction speed so as to prevent cavitation when delivering viscous or gaseous liquid.

Select 100% (default), 75%, 50% or 25%.

■ Diaphragm position adjustment (See page 47 & 48)

A pump shaft expands or contracts to help diaphragm replacement.

Select "MAX OUT Pos." through the "Other Features" menu in order to extend the pump shaft to the maximum for the replacement of the diaphragm. Select "MAX IN Pos." to contract the pump shaft and mount the pump head. See page 59 "Diaphragm replacement" for detail.

■ Anti chattering programming (See page 47 & 48)

Program a pulse recognition time for the IX not to be adversely affected by chattering or noise.

Factory default setting is 5msec. This means the pump recognizes a pulse length of 5msec or more. Select 1 or 2msec if a pulse length is shorter than 5msec, however, note the shorter the recognition time is, the more susceptible to the interference of noise the pump becomes.

Note the maximum allowable input frequency of the IX is 100Hz.

■ Flow unit setting (See page 47 & 48)

Select L/H or GPH for flow rate indication.

■ Language setting (See page 47 & 49)

Select your language through language selection.

■ Keypad lock (See page 52)

Activate keypad lock for the prevention of erroneous key operation.

■ Default

Power on the pump while pressing the ESC key to recall default setting. Note the flow volume per shot obtained through the calibration process (see page 35) remains the same.

Part names

Pump

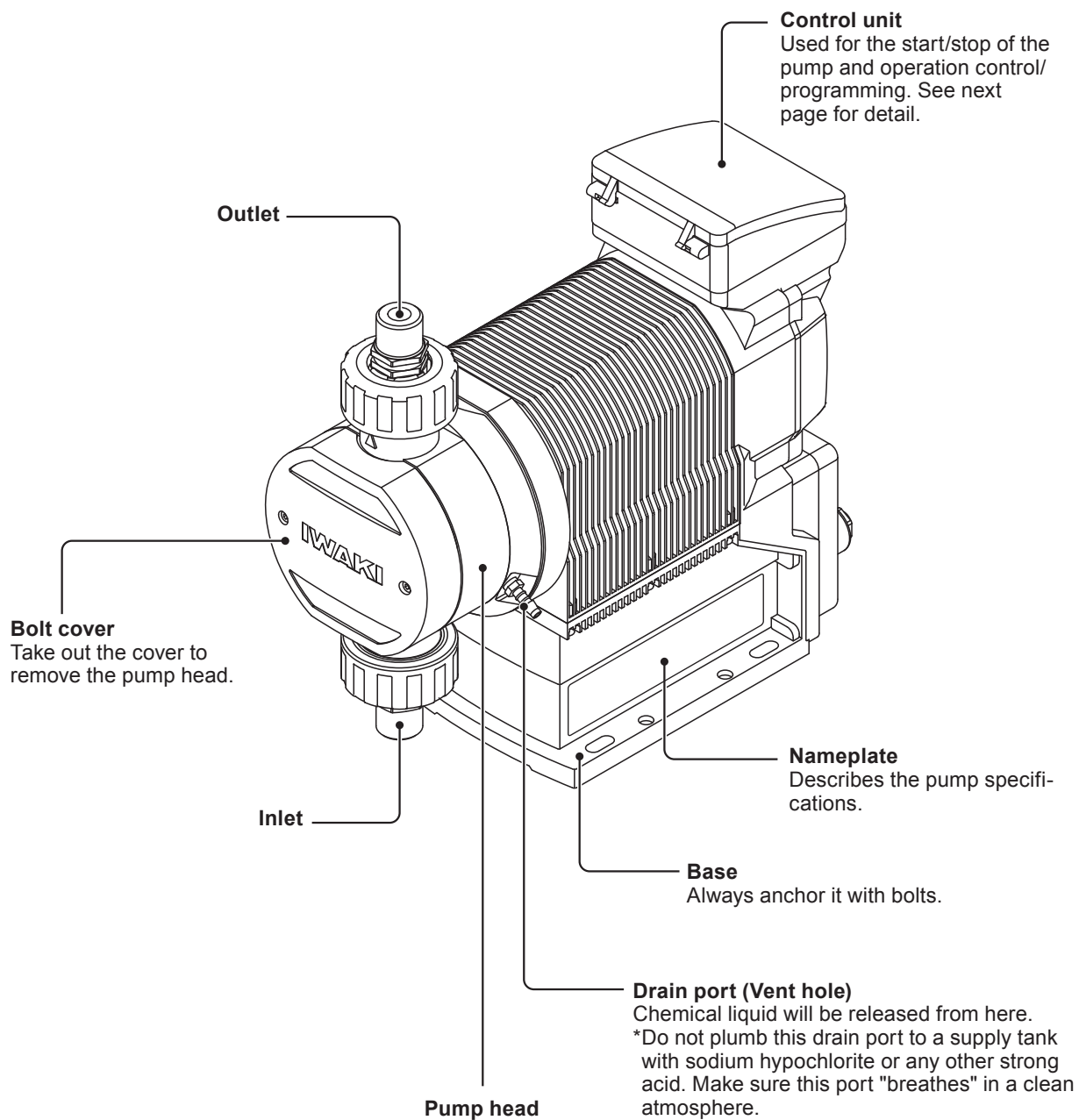

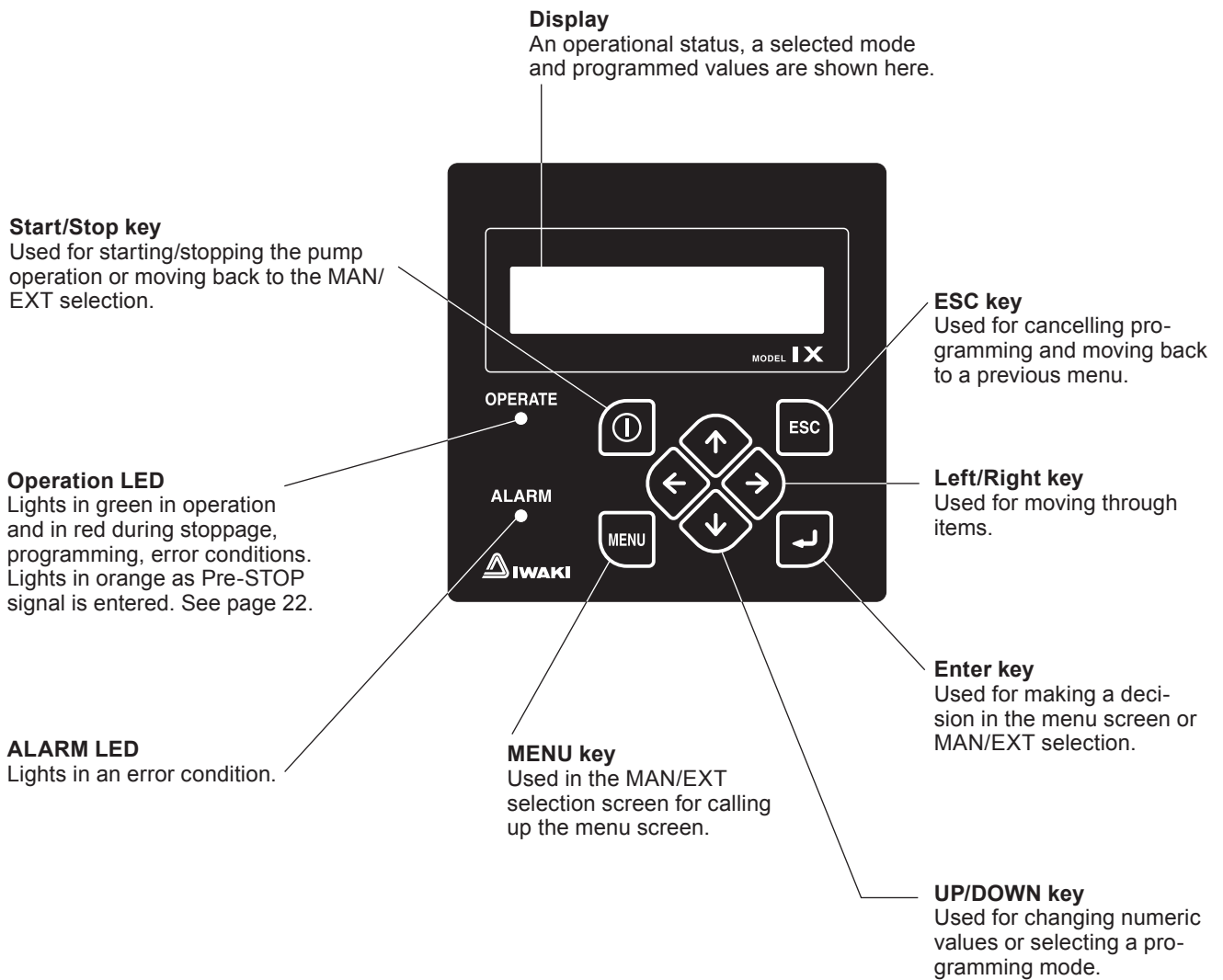

■ Basic displays and Pump states

	Display	Operation LED lights in red	Operation LED lights in green	Operation LED lights in orange	ALARM LED lights in red
Operation	PUMP On (Manual) 150 L/H	—	Operation in manual mode	—	—
	PUMP On (Analog) 150 L/H	—	Operation in EXT mode (Analogue control)	—	—
	PUMP On (AUX) 150 L/H	—	AUX operation	—	—
	PRIMING OVERRIDE @ 150 L/H	—	Operation in priming mode	—	—
	Pre-Stop (MAN*) 150 L/H	—	—	Pre-STOP function is active.	—*
Stop	Standby (Manual) 150 L/H	A wait state in manual mode	—	—	—
	Standby (EXT) Analog	A wait state in EXT mode (analogue control)	—	—	—
	SELECT OPERATION MAN ← → EXT (ANALOG)	MAN/EXT selection	—	—	—
	MAIN MENU: ← Program EXT →	Menu screen	—	—	—
	MOTOR OVERLOAD! S/S Key = Clear	Pressure overload protection is active.	—	—	—*
	LEAK DETECTED! S/S Key = Clear	Diaphragm is broken.	—	—	Leak detection (Alarm 1 default setting)*
	DRIVE ERROR! S/S Key = Clear	Sensor failure	—	—	—
	Stop (Manual) -----	Operation stop in manual mode	—	—	—*
	Interlock (MAN*) -----	—	—	—	Interlock function activation (Alarm 2 default setting)*

*The Alarm LED becomes active when a function is allocated to Alarm 1 or 2.

Identification codes

Each code represents the following information.

Pump

IX - C 150 TC N - TB - U

a b c d e f g h

a. Series name

b. Drive unit

c. Pump unit (Max flow)

150 : 150 [L/H]

060 : 60 [L/H]

d. Wet end materials

Code	Pump head	Ball valve	Valve seat	O ring	Valve gasket	Diaphragm
TC	PVDF	CE	FKM	FKM	—	PTFE+EPDM*
TE			EPDM	EPDM		
S6	SUS316	SUS316	SUS316	—	PTFE	

*EPDM is not a wet end.

Material code

PVDF : Polyvinylidene difluoride

PTFE : Polytetrafluoroethylene

EPDM : Ethylene-propylene rubber

FKM : Fluorine-contained rubber

CE : Ceramics

SUS316 : Austenite stainless

e. Connection

N : NPT thread FA : ANSI flange

f. Controller housing

TF : Top Front TB : Top Back TR : Top Right TL : Top Left RF : Right Face LF : Left Face

g. Power plug

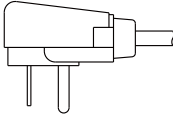
Code	U	U2
Plug shape		
	115V (2m length)	230V (2m length)

h. Special version

No code : Standard

: Customized models will be coded.

Installation

This section describes the installation of the pump, piping and wiring. Read through this section before work.

! Points to be observed

Observe the following points when installing the pump.

- Be sure to turn off power to stop the pump and related devices before work.
- Upon sensing abnormality or danger, stop work immediately. Remove problems before resuming work.
- Do not place dangerous or flammable goods near the pump for your safety.
- Risk of an electrical leak or shock. Do not use a damaged pump.

Pump mounting

Select an installation location and mount the pump.

Necessary tools

- Four M8 bolts (pump mounting)
- Adjustable wrench or spanner

- 1 Select a suitable place.
Always select a flat floor free of vibrations. See page 10 for detail.

- 2 Anchor the pump by four M8 bolts.
Be sure to fix the pump at four points.

NOTE

Install the pump horizontally. If the pump is installed at a tilt, the flow may reduce.

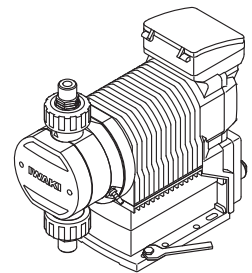

Pipework

■ Piping layout

Flooded suction application

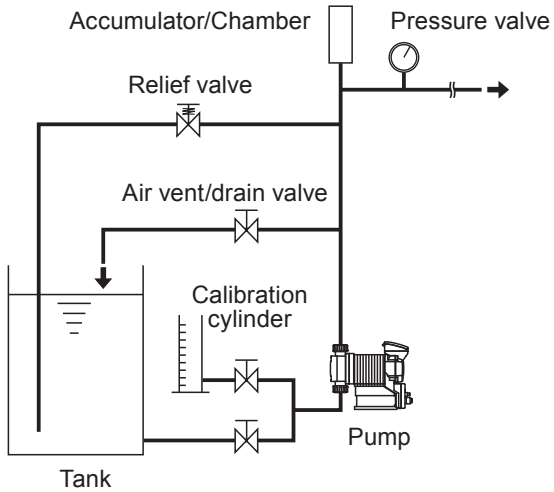

Suction lift application

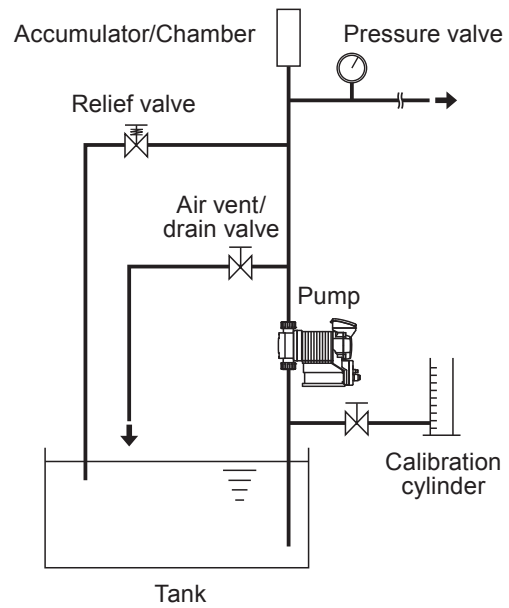

NOTE

- A suction line bore should be wider than the inlet bore of the pump.
- Flooded suction is recommended when handling a gaseous liquid such as sodium hypochlorite or high-viscosity liquid.
- Observe the permitted force of 100N and moment of 10N•m to the inlet and outlet of the pump head. Support your piping system as necessary so as not to go over the allowable moment.

Drain port (Vent hole)

Leaked liquid drains through a drain port at the time of accidental diaphragm rupture. Use a chemically-resistant tube to the drain port to collect the liquid in a tank.

NOTE

- Do not plug the drain port. The port functions as a vent hole to keep the pressure in the pump head constant.
- Do not immerse the tube end in liquid, or liquid may be pumped up through the drain port in operation.

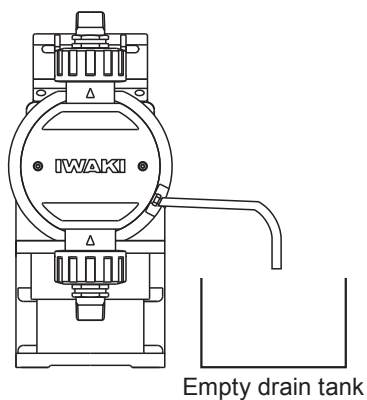
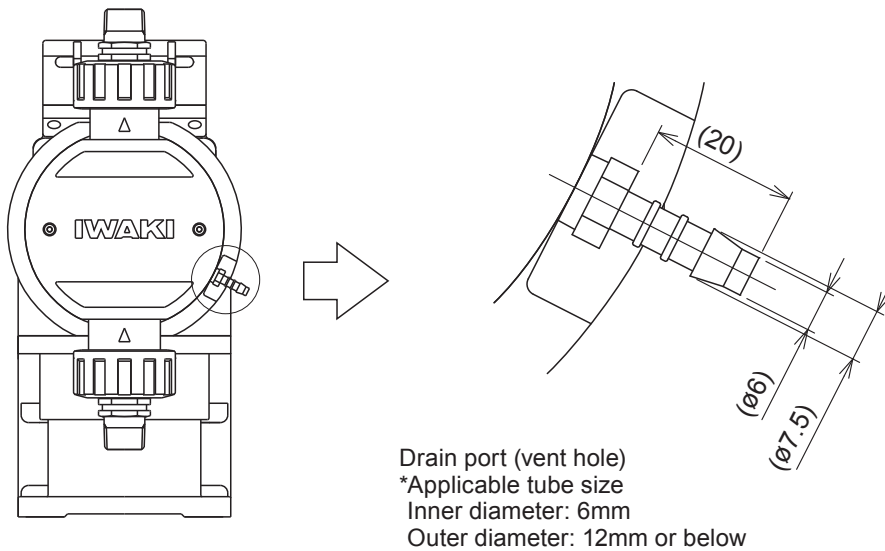

Do not place the drain tube end below a liquid level.



Do not suck up fumes from corrosive chemicals such as sodium hypochlorite.

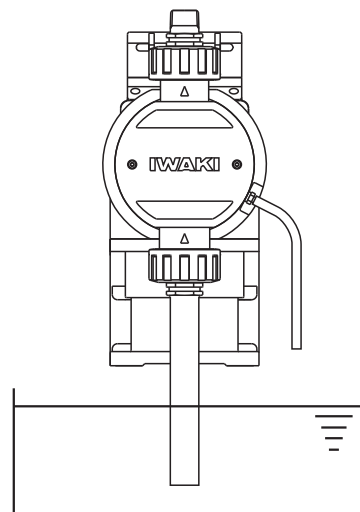
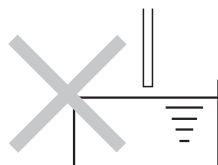

Noncorrosive chemicals in a supply tank. The drain tube end must stay above a liquid level.

Wiring

Wiring for power voltage, earthing and external signals.

! Points to be observed

Observe the following points during wiring work.

- Electrical work should be performed by a qualified operator. Always observe applicable codes or regulations.
- Observe the rated voltage range, or the electrical circuit in the control unit may fail.
- Do not perform wiring work while electric power is on. Otherwise, an electrical shock or a short circuit may result. Be sure to turn off the power before wiring work.
- Be careful for electric power not to be turned on during work.
- Replacement of a power cable should be conducted by a manufacturer, his agency or a skilled person. Otherwise, an accident may result.

End terminals

See the following diagram for detail.

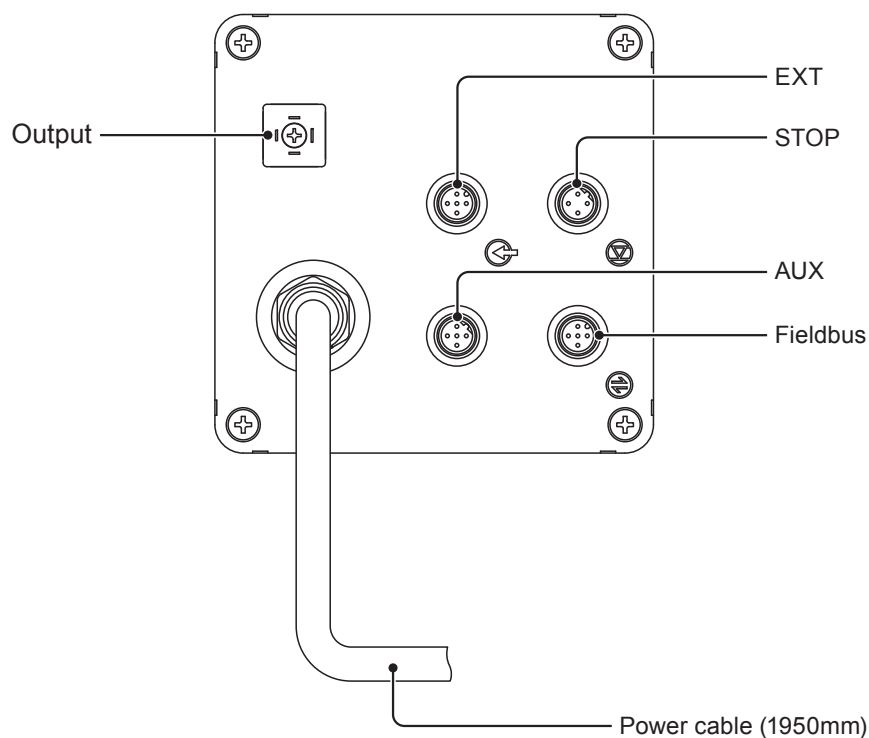

Power voltage/Earthing

Points to be checked

- Check that power voltage is turned off.

1 Insert the plug all the way seated in a socket.

NOTE

- Do not share a power source with a high power device which may generate surge voltage. Otherwise an electronic circuit may fail. The noise caused by an inverter also affects the circuit.
- Energize the pump with a power voltage via a mechanical relay or switch. Do not fluctuate the voltage, or CPU may malfunction. See page 29 for the precautions for ON-OFF control by a mechanical relay.

When power voltage is applied at a sitting

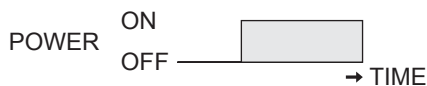

When power voltage is applied gradually



Surge voltage

The electronic circuit in the control unit may fail due to surge voltage. Do not place the pump close to a high power device of 200V or more which may generate large surge voltage. Otherwise, take any of the following measures.

- Install a surge absorption element (such as a varistor with capacity of 2000A or more) via power cable or,

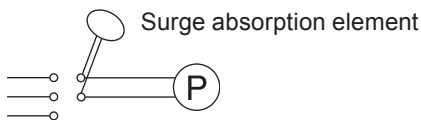

Recommended varistors

Panasonic ERZV14D431

KOA NVD14UCD430

See manufacturer's catalogues for detail.

- A noise cut transformer via the power cable.

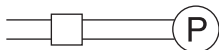

Noise cut transformer

Precautions for ON-OFF control by a mechanical relay

The control unit is equipped with CPU. Always start/stop the pump by the STOP signal for ON-OFF control. Try not to turn on and off the main power. Otherwise, observe the following points.

- Do not turn ON/OFF power voltage more than six times per hour.
- When using a mechanical relay for ON-OFF operation, its contact capacity should be 5A or more. Contact point may fail if it is less than 5A.
- If a mechanical relay with the contact capacity of 5A is used, the maximum allowable ON/OFF operation is about 150,000 times. The contact capacity should be 10A or more when making ON-OFF operation over 150,000 times or sharing a power source with a large capacity equipment. Otherwise a contact point may fail by surge voltage.
- Use a solid state relay (SSR) as necessary (such as the OMRON G3F). See manufacturer's catalogues for detail.
- Turning off power voltage, operation stops with an extended pump shaft after the completion of the last discharge process.

Signal wire connection

Points to be checked

- Check that power voltage is turned off.

Use our optional connector cables below or purchase DIN 4- and 5-pin female connector cables when using signal input and output.

Optional 5m DIN connector cables

EXT terminal is for Input signal

STOP terminal is for STOP and AUX signals

OUT terminal is for Output signal

NOTE

- Do not lay on these signal cables in parallel with a power cable. Otherwise noise is generated through the cables due to induction effect and it results in malfunction or failure.
- The following products are the recommended SSRs (Solid State Relays) for signal input. Any other SSRs may cause malfunction. See manufacturer's information for details on these SSRs.
 - OMRON G3FD-102S or G3FD-102SN
 - OMRON G3TA-IDZR02S or G3TA-IDZR02SM
- When using a mechanical relay for signal input, its minimum application load should be 5mA or below.
- Insert the DIN 4- or 5-pin female connector as far as it will go and then tighten the skirt to make a secure connection.

*Use either a no-voltage contact or an open collector for the input, STOP and AUX signals.

■ Input signal

To make pulse-, batch-, interval batch- and analogue-control operation or to activate interlock function, connect signal wires to the EXT terminals via the DIN 5-pin connection.

When using an open collector...

Pay attention to polarity. Pulse (1) and Interlock (2) are plus (+), and COM (4) is minus (-).

When using a no-voltage contact...

Use a mechanical relay designed for an electronic circuit. Its minimum application load should be 5mA or less.

When using analogue control...

Pay attention to polarity. Analogue (3) is plus (+) and COM (4) is minus (-). Internal resistance is 200Ω.

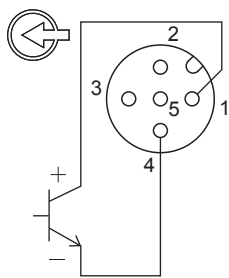

Wiring for
Pulse-, batch-, interval
batch-control

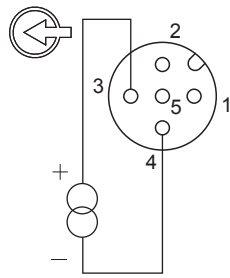

Wiring for
Analogue control

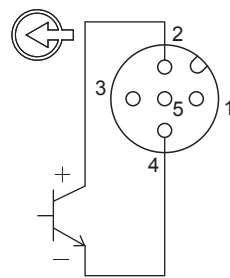

Wiring for
Interlock function

- 1 : Pulse (Brown)
 - 2 : Interlock (White)
 - 3 : Analogue (Blue)
 - 4 : COM (Black)
 - 5 : 12VDC30mA or below (Green)
- *Each wire is coloured as above for our optional cable. The terminal 5 is an output and is not used. Do not short-circuit this terminal to COM (4).

■ STOP signal

To activate STOP function, connect signal wires to the STOP terminal via the DIN 4-pin connection.

When using an open collector...

Pay attention to polarity. STOP (1) and Pre-STOP (2) are plus (+), and COM (4) is minus (-).

When using a no-voltage contact...

Use a mechanical relay designed for an electronic circuit. Its minimum application load should be 5mA or less.

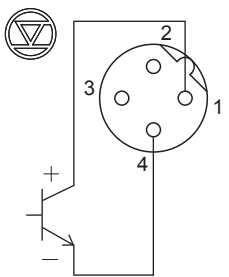

Wiring for
STOP function

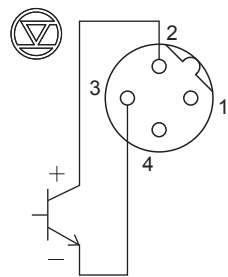

Wiring for
Pre-STOP function

- 1 : STOP (Brown)
 - 2 : Pre-STOP (White)
 - 3 : COM (Blue)
 - 4 : COM (Black)
- *Each wire is coloured as above for our optional cable.

NOTE

Our optional cable has 5 wires. Cut off a green wire to use it with the DIN 4-pin connector.

■ AUX signal

To activate AUX function, connect signal wires to the AUX terminal via the DIN 5-pin connection.

When using an open collector...

Pay attention to polarity. AUX (3) is plus (+), and COM (4) is minus (-).

When using a no-voltage contact...

Use a mechanical relay designed for an electronic circuit. Its minimum application load should be 5mA or less.

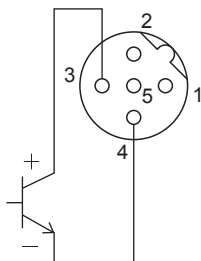

Wiring for
AUX function

- 1 : N.C. (Brown)
- 2 : N.C. (White)
- 3 : AUX (Blue)
- 4 : COM (Black)
- 5 : 12VDC30mA or below (Green)

*Each wire is coloured as above for our optional cable. The terminal 5 is an output and is not used. Do not short-circuit this terminal to COM (4).

■ Output signal

To transmit signal to an external device, connect signal wires to the OUT terminal via the DIN 4-pin connection.

Alarm1<Mechanical relay>: Enable or disable STOP, Pre-STOP, Interlock, Motor overload and Leak detection individually.

*Leak detection only is enabled at factory default setting.

Alarm2<PhotoMOS relay>: Enable or disable STOP, Pre-STOP, Interlock, Motor overload and Leak detection individually.

*Interlock only is enabled at factory default setting.

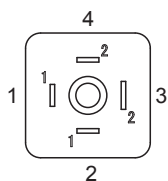

- 1 : Alarm1 (White)
- 2 : Alarm1 (Brown)
- 3 : Alarm2 (Black)
- 4 : Alarm2 (Blue)

*Each wire is coloured as above for our optional cable.

Mounting direction of the output signal cable

Mount the DIN square connector cable in the following direction and secure it with a M3 screw.

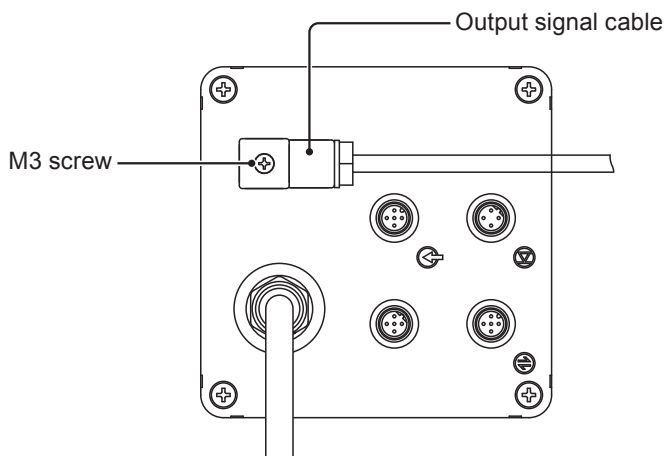

Operation

This section describes pump operation and programming. Run the pump after pipework and wiring are completed.

Before operation

First check piping and wiring are correct. And then make commissioning before starting operation.

Points to be checked

Before operation, check if...

- Liquid level in a supply tank is enough.
- Piping is securely connected and is free from leakage and clogging.
- Discharge/suction valves are opened.
- Power voltage range is correct.
- Electrical wiring is correct and is free from the risk of short circuit and electrical leakage.

Retightening of pump head fixing bolts

Important

The pump head fixing bolts may loosen when plastic parts creep due to temperature change in storage or in transit, and this can lead to leakage. Be sure to retighten the bolts evenly to the specified tightening torque below in diagonal order before starting operation.

Tightening torque

Model code	Torque	Bolts	Number of bolts
IX-C150	12 N•m	M8 hexagon head bolt	8
IX-C060	3.5 N•m	M5 hexagon head bolt	6

*Tighten fixing bolts once every three months.

Commissioning

Always make commissioning when first mounting the pump in your system or resuming operation after a long period of stoppage.

- 1 Open an air vent and a suction line.
Do not open a calibration line if any.

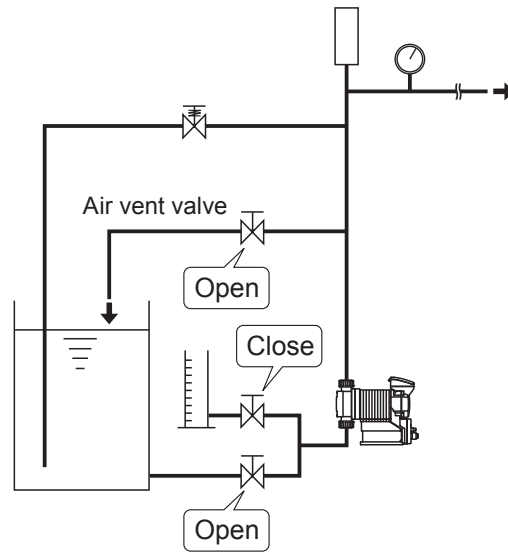

- 2 Supply the rated power voltage to the pump.
- 3 Start the pump at a low flow rate and gradually increase it to a target rate.
Continue operation for 10 minutes and check the pump and pipework for any abnormality.
- 4 Close an air vent line to pump liquid to a main line.

Before a long period of stoppage (One month or more)

Clean wet ends and the inside of piping.

- Run the pump with clean water for about 30 minutes to rinse chemicals off.

Before unplugging the pump

- Always stop the pump by key operation and wait for three seconds before unplugging the pump. Otherwise, the last key operation may not be put in memory. In this case the pump unintentionally starts to run as powered on, discharging liquid.

When the pump does not transfer liquid at resuming operation.

- Clean the valve sets and remove foreign matters.
- If air is in the pump head, expel air through the above commissioning procedure.

Perform a calibration

Periodically make calibration to monitor an accurate flow through control display. The pump is calibrated by pumping clean water at the maximum operating pressure before shipping (in the absence of a designation by a user), however, make calibration again in an actual operating condition as necessary. Follow the calibration process on the next page.

NOTE

- A flow rate shown on the screen is calculated one based on calibration and is not an actual flow rate.

Calibration is made to determine liquid volume per shot. Arrange your piping system based on the diagram below.

Suggested piping layout

Use a calibration cylinder connected to a suction line.

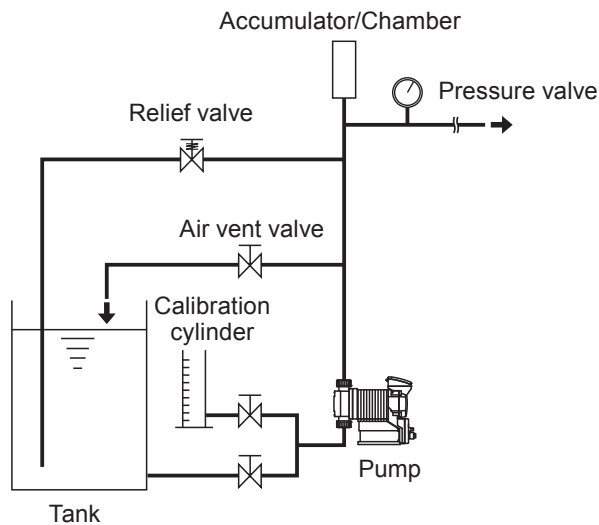

Bad example

Do not immerse a calibration tube in liquid level in a calibration cylinder. Otherwise, tube volume is added to the liquid volume to be measured, and calibration will be upset.

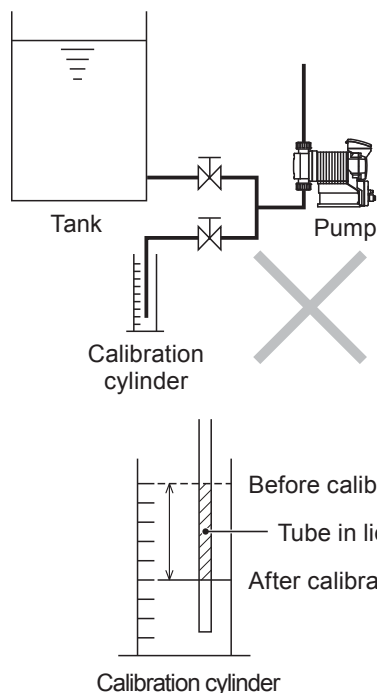

Calibration process

Obtain accurate flow volume per shot (e.g. about 16ml/shot for the 150C type, about 6ml/shot for the C060 type) by dividing the delivered liquid volume by the number of strokes.

1 Fill a calibration cylinder with liquid.

Open a calibration line to lead liquid from a supply tank to a calibration cylinder. And then close the suction line and measure liquid volume in the cylinder.

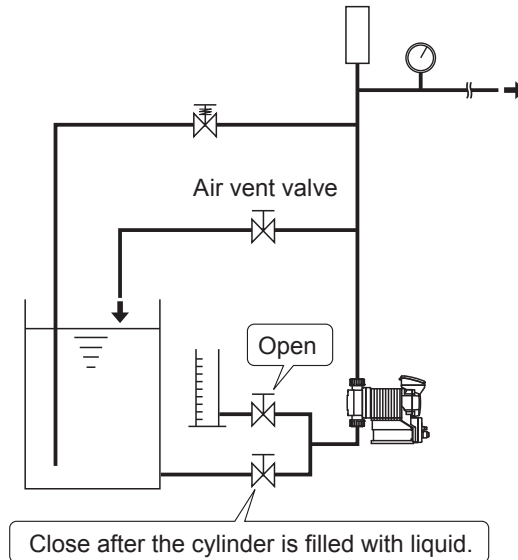

2 Supply the rated power voltage to the pump and programme the maximum flow rate in the manual mode.

See page 50 for detail.

NOTE

Calibration can be made at a slower flow rate, but then it takes longer time than the maximum rate.

3 Select the calibration mode through the menu screen.

See page 39 for detail.

4 Calibration operation programming

Set a waiting time and the number of strokes. The number of strokes should be determined depending on how much liquid remains in the calibration cylinder.

Waiting time to start calibration operation : 10(default)-999s

Number of strokes : 60(default)-120ST

```

Wait Time: 10s
# Strokes: 60ST
    
```

Use UP and DOWN keys to set a waiting time.



```

Wait Time: 20s
# Strokes: 60ST
    
```

Use UP and DOWN keys to set the number of strokes.

5 Start calibration operation.

```
Wait Time: 20s
# Strokes: 100ST
```

```
20
:
19
:
18
:
17
```

Push the Enter key after setting the number of strokes. The pump starts a countdown.



```
Wait Time: 0s
# Strokes: 100ST
```

```
Pump
starts
```

The pump starts to run for the set number of strokes as it comes to zero.



```
Wait Time: 0s
# Strokes: 99ST
```

```
99
:
98
:
97
```



```
Wait Time: 0s
# Strokes: 0ST
```

```
Pump
stops
```

6 Measure liquid volume in the calibration cylinder again.

7 Enter how much liquid has reduced.

```
Enter Volume:
0 mL
```

Use the UP and DOWN keys to set the volume reduction.



```
Enter Volume:
1650 mL
```



```
Volume/Stroke:
16.50mL
```

Push the Enter key once. The screen shows flow volume per shot. Calibration now has been completed.

*The screen shows "ERROR! Volume Out Of Range!!" if the reduction is too little or too large. Enter correct liquid volume or recalibrate it.



```
MAIN MENU:
← Calibration →
```

NOTE

Calibration with high viscosity liquid at a full suction speed will often give rise to this error. Reduce a suction speed along with viscosity.



```
SELECT OPERATION
MAN← →EXT(ANALG)
```

Push the ESC key to return to the wait mode.

Operation programming

The pump operation is programmed and controlled by a control unit in different ways at each operation mode.

Mode	Parameters	Setting ranges	Default
Mode selection	-	MAN/EXT	MAN
External control	Analogue control	0-20mA/ 4-20mA/ 20-0mA/ 20-4mA	4-20mA
	Pulse control	0.01560mL/PLS-300mL/PLS (C150)	0.01560mL/PLS
		0.00625mL/PLS-120mL/PLS (C060)	0.00625mL/PLS
	Batch control	15.6mL/PLS-300L/PLS (C150)	15.6mL/PLS
		6.25mL/PLS-120L/PLS (C060)	6.25mL/PLS
	Interval Batch control	0-9day, 0-23Hr, 1-59min	0D : 0H : 1M
15.6mL-300L/PLS (C150) 6.25mL-120L/PLS (C060)		15.6mL/PLS 6.25mL/PLS	
Profibus control	Address : 1-127	50	
Signal input	STOP	Closed = Pump OFF/ Closed = Pump ON	Closed = Pump OFF
	PreSTOP	Closed = Pump OFF/ Closed = Pump ON	Closed = Pump OFF
	Interlock	Closed = Pump OFF/ Closed = Pump ON	Closed = Pump OFF
	Leak detection	Enable/ Disable	Enable
Alarm	Alarm 1	STOP/ Pre-STOP/ Interlock Leak Detection/ Motor Overload	Leak Detection
	Alarm 2	STOP/ Pre-STOP/ Interlock Leak Detection/ Motor Overload	Interlock
Others	Suction speed	100%/ 75%/ 50%/ 25%	100%
	AUX speed	200mL/H-150L/H (C150)	150L/H
		80mL/H-60.0L/H (C060)	60.0L/H
	Diaphragm position	MAX OUT Pos./ MAX IN Pos.	MAX OUT Pos.
	Anti-Chattering	1msec/ 2msec/ 5msec	5msec
Unit	Liter/ US gallon	Liter	

*A value increases/decreases step by step every time the UP/DOWN keys is pushed. Press and hold either key for quick change.

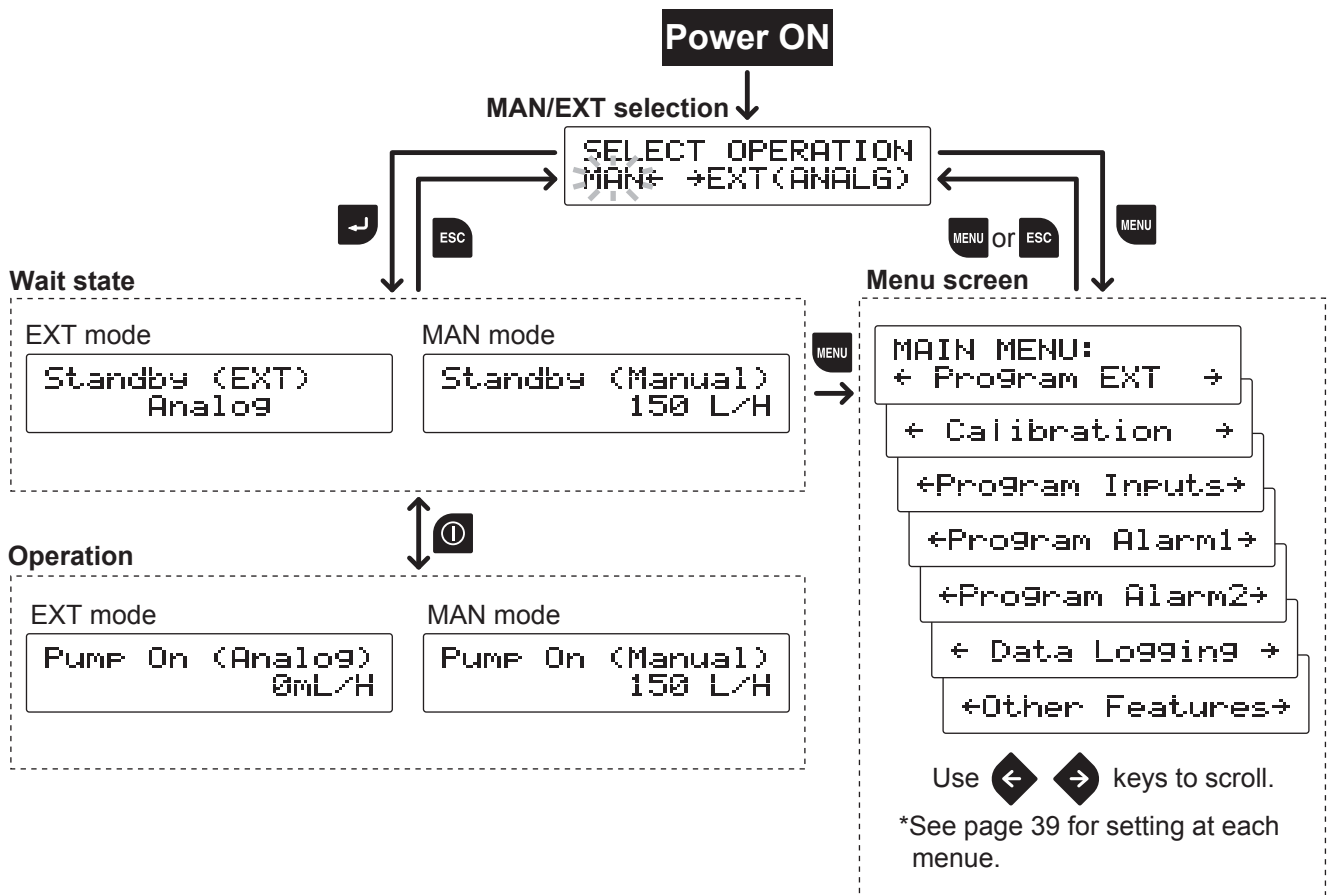

Menu screen

Push the MENU key in the MAN/EXT selection mode and call up the menu screen. Use the right and left keys to scroll through each menu item and then push the Enter key to make a selection. Pushing the MENU key again or ESC key in the menu screen, the previous mode will be recalled.

```
MAIN MENU:  
← Program EXT →
```

EXT mode selection

The pump can run in four different operating modes of Analogue, Pulse, Batch and Interval Batch for the external signal. See page 14, 15 and 40 for detail.

```
MAIN MENU:  
← Calibration →
```

Calibration

Calibrate the pump to obtain a correct flow rate on the screen. See page 35, 36 and 42.

```
MAIN MENU:  
←Program Inputs→
```

Signal input setting

Program STOP, Pre-STOP, Interlock functions and diaphragm rupture detection. See page 17, 18, 42 and 43.

```
MAIN MENU:  
←Program Alarm1→
```

Alarm 1 setting

Enable or disable the Alarm 1 for STOP, Pre-STOP, Interlock and/or diaphragm rupture detection. See page 19 and 44.

```
MAIN MENU:  
←Program Alarm2→
```

Alarm 2 setting

Enable or disable the Alarm 2 for STOP, Pre-STOP, Interlock and/or diaphragm rupture detection. See page 19 and 45.

```
MAIN MENU:  
← Data Logging →
```

Data logging

The pump can display operating time, total flow volume, power-on time, the number of ON/OFF and software version. See page 46.

```
MAIN MENU:  
←Other Features→
```

Programming of other functions

Program a suction speed, an AUX speed, a diaphragm position, anti-chattering, flow rate unit and your language. See page 19, 47, 48 and 49.

■ EXT mode selection

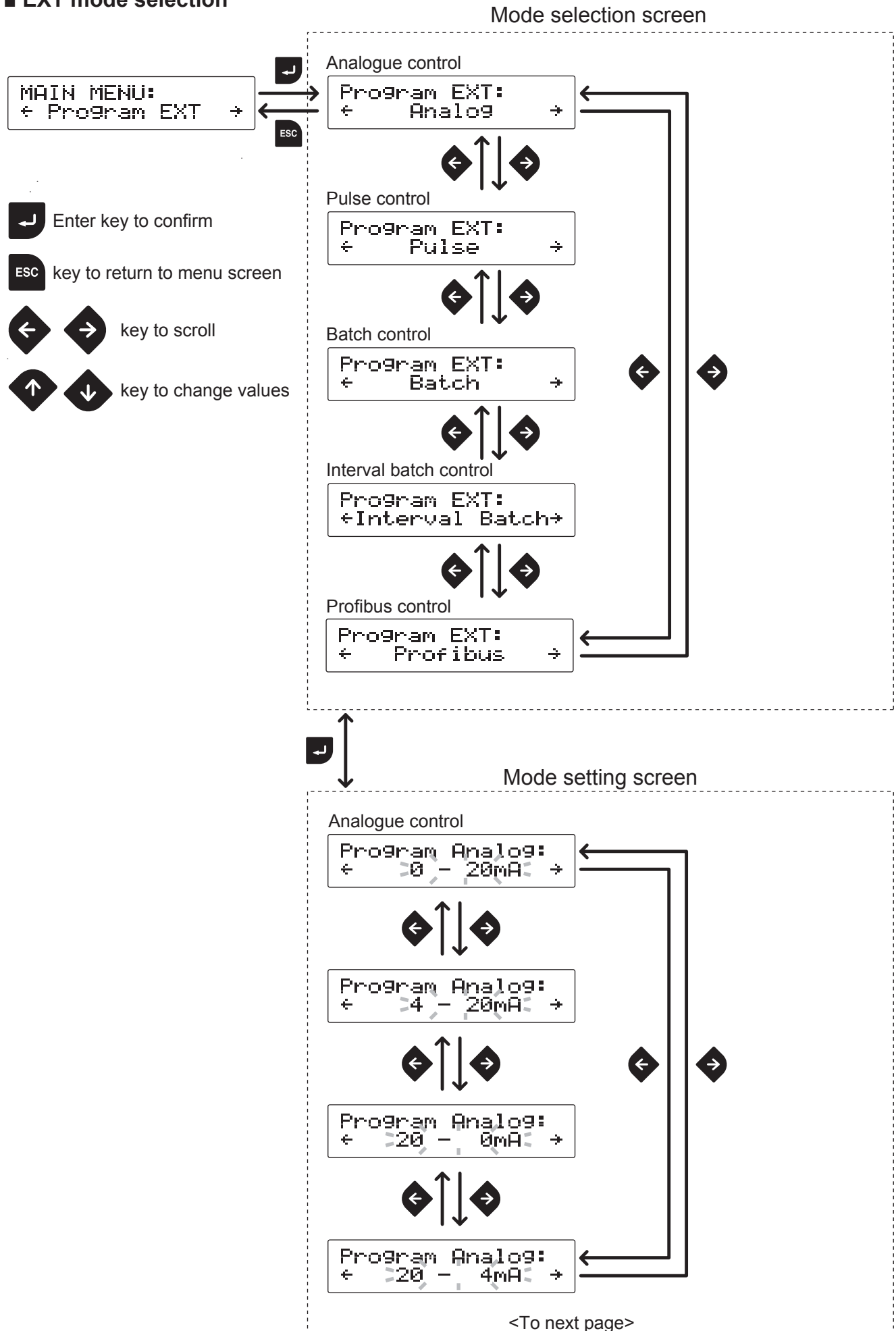

<To next page>

Pulse control

```
Program Pulse:  
0.01560 mL/PLS
```

Set flow volume per pulse.

Batch control

```
Program Batch:  
15.6 mL/PLS
```

Set flow volume per pulse.

Interval batch control

```
SET Interval  
Time: 00 0H 1M
```

Set "Day".



```
SET Interval  
Time: 00 0H 1M
```

Set "Hour".



```
SET Interval  
Time: 00 0H 1M
```

Set "Minute".



```
Volume: 7.50 L
```

Set a flow rate.

Profibus control

```
SET Profibus:  
Address: 50
```

Set an address.

■ Calibration

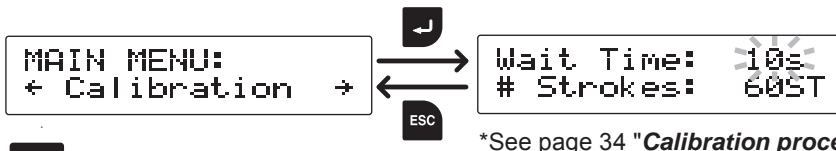

*See page 34 "**Calibration process**" for detail.

Enter key to confirm

key to return to menu screen

key to select

key to change values

■ Signal input setting

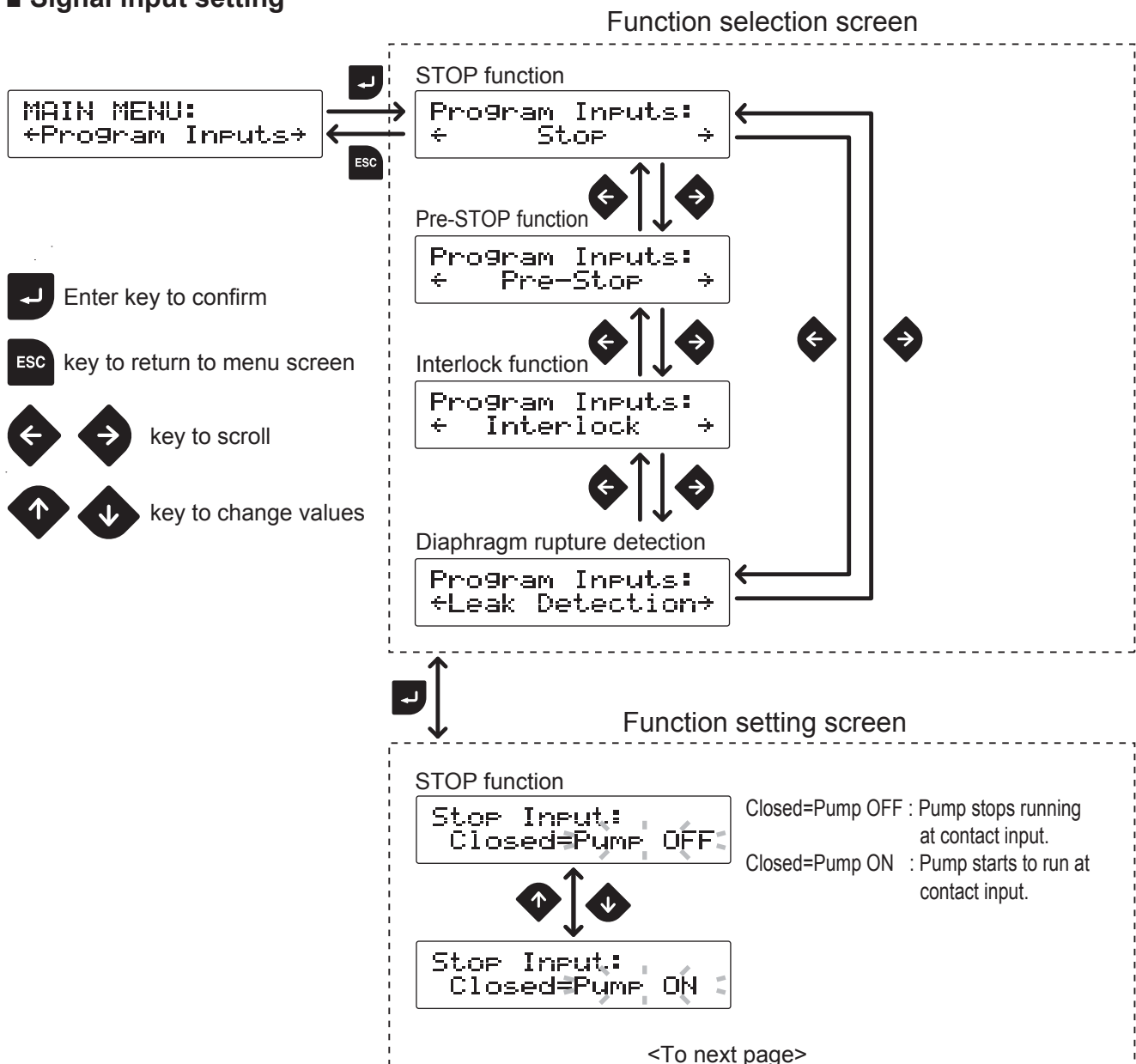

Pre-STOP function

```
Pre-Stop Input;
Closed=Pump OFF;
```

Closed=Pump OFF : Operation LED lights in orange at contact input.
 Closed=Pump ON : Operation LED does not lights at contact input.



```
Pre-Stop Input;
Closed=Pump ON;
```

Interlock function

```
Interlock;
Closed=Pump OFF;
```

Closed=Pump OFF : Pump stops running at contact input.
 Closed=Pump ON : Pump starts to run at contact input.



```
Interlock;
Closed=Pump ON;
```

Diaphragm rupture detection

```
Leak Detection;
Disable;
```

Disable : Rupture detection is not used.
 Enable : Rupture detection is used.



```
Leak Detection;
Enable;
```

■ Alarm 1 setting : OUT1<Mechanical relay>

Output selection screen

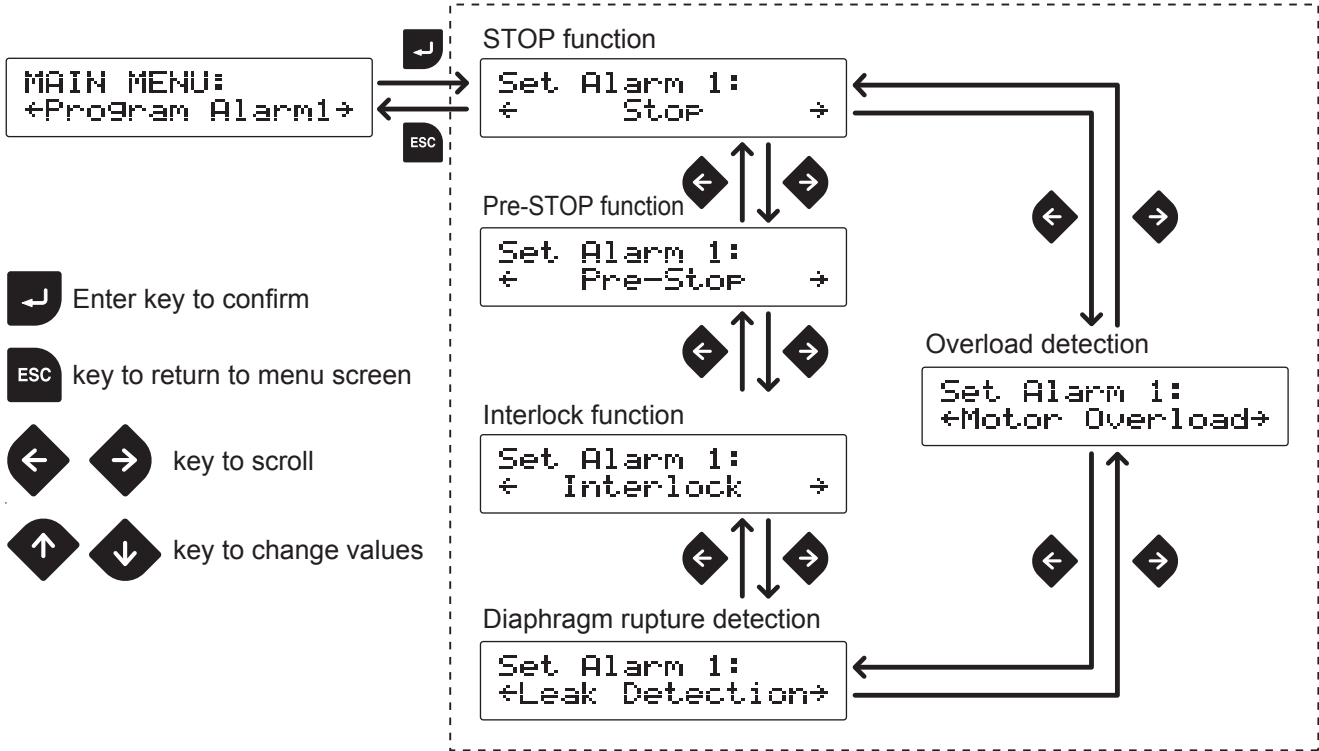

- Enter key to confirm
- ESC key to return to menu screen
- key to scroll
- key to change values

Output setting screen

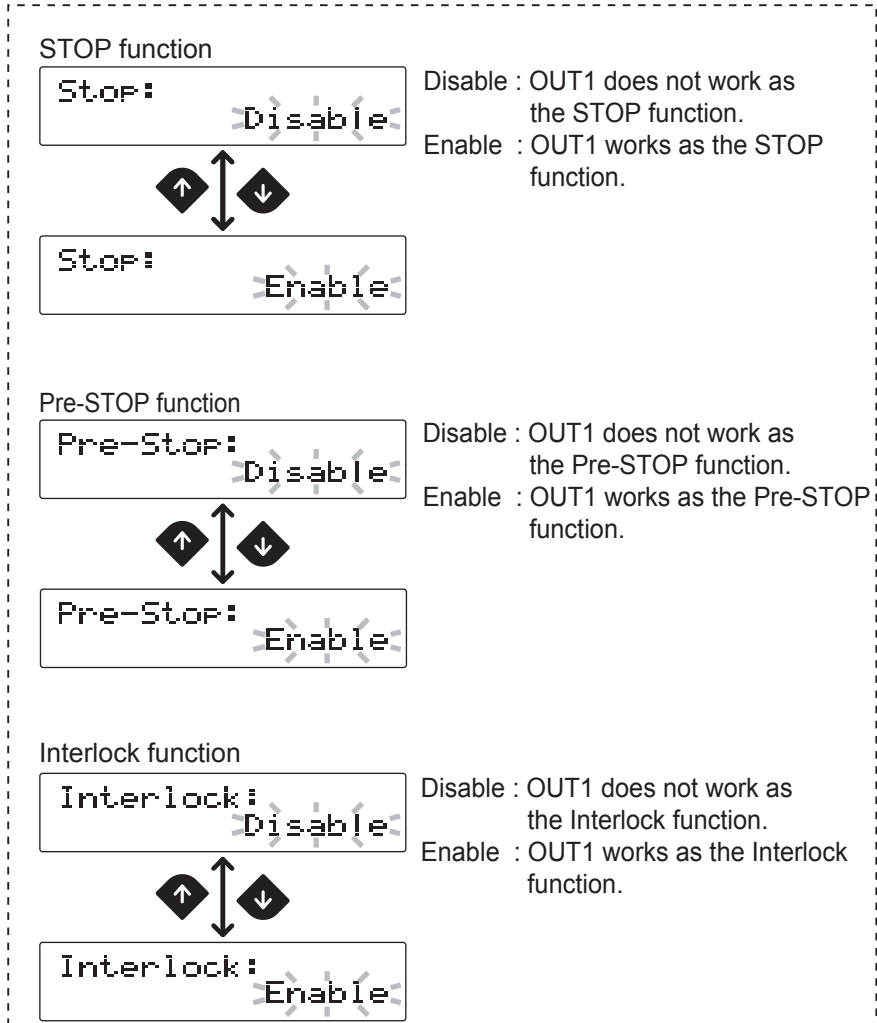

- Disable : OUT1 does not work as the STOP function.
- Enable : OUT1 works as the STOP function.
- Disable : OUT1 does not work as the Pre-STOP function.
- Enable : OUT1 works as the Pre-STOP function.
- Disable : OUT1 does not work as the Interlock function.
- Enable : OUT1 works as the Interlock function.

<To next page>

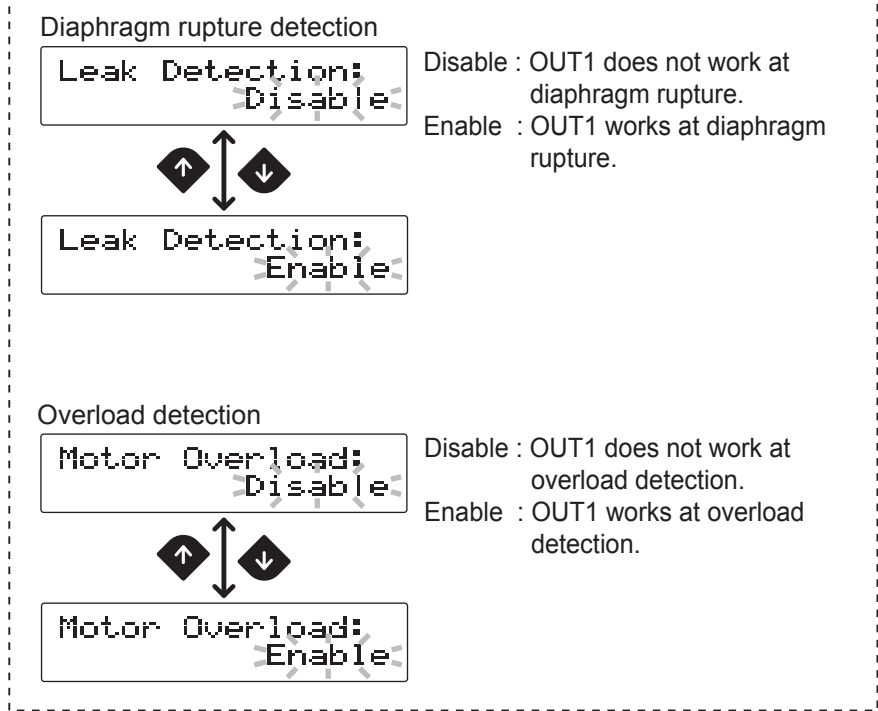

■ Alarm 2 setting : OUT2<PhotoMOS relay>



Alarm 2 is programmed in the same way as the Alarm1.

■ Data logging

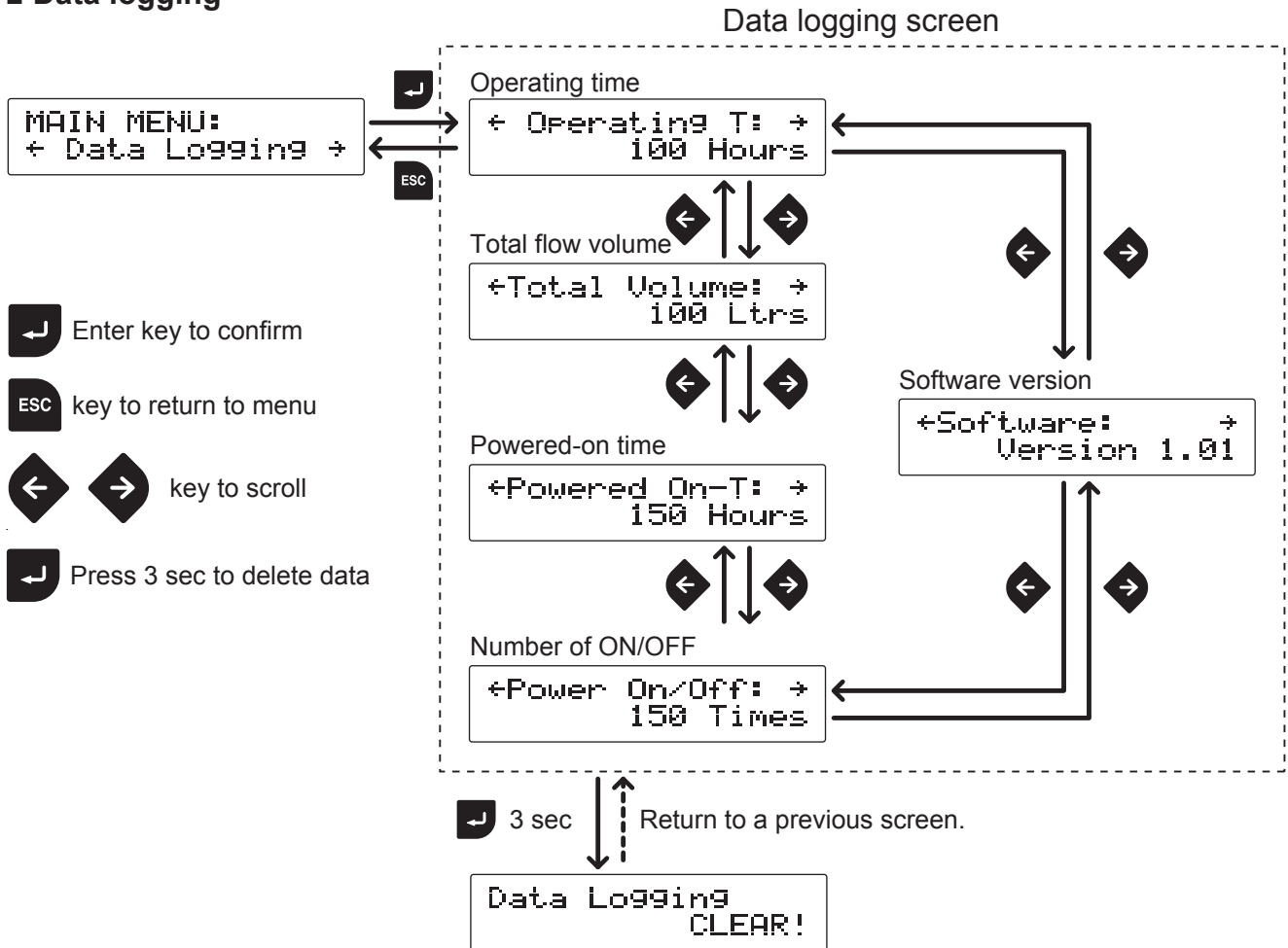

*A selected data will be cleared except the version information.

■ Programming of other functions

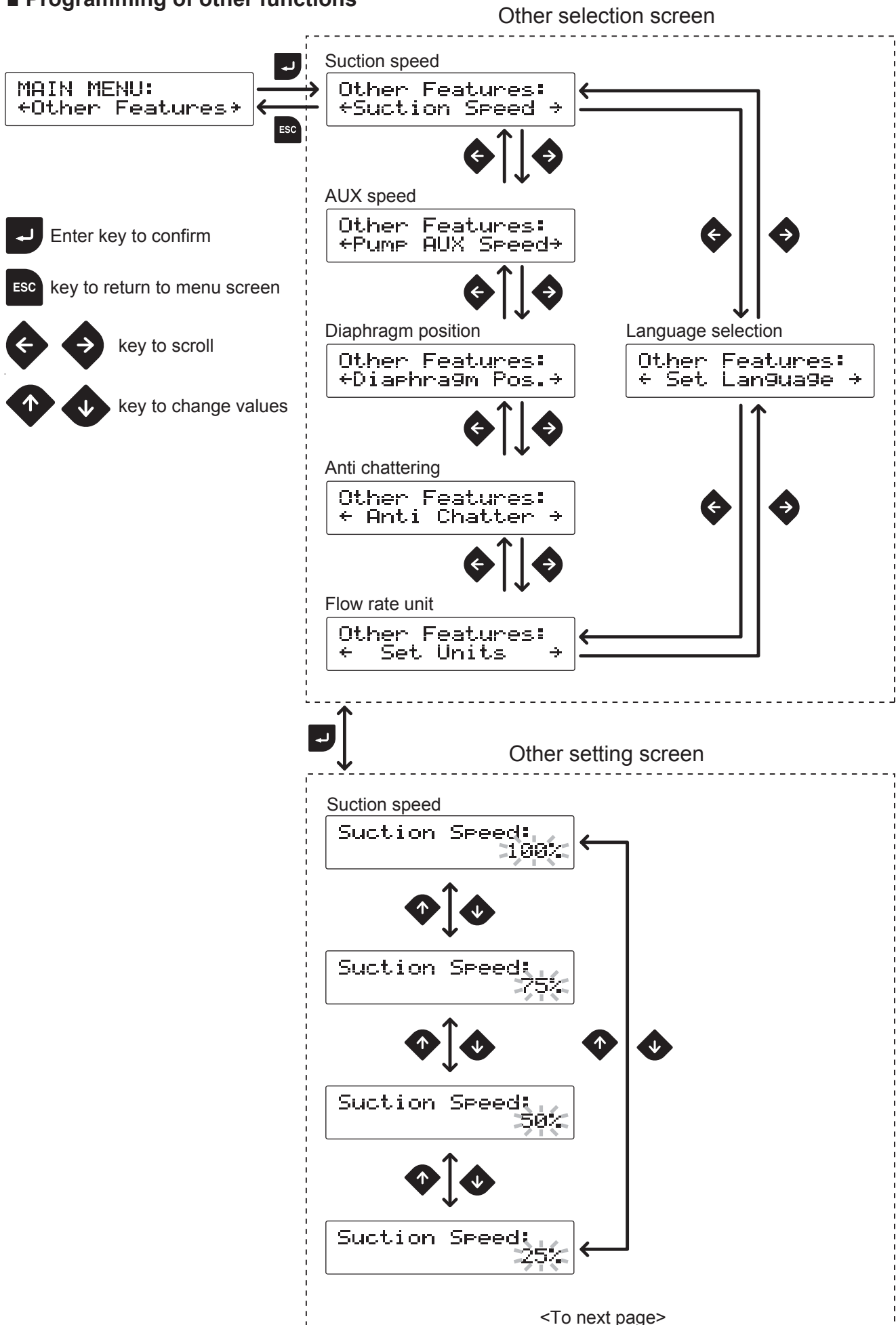

AUX speed

Pump AUX Speed:
50.0 L/H

Set a flow rate.

Diaphragm position

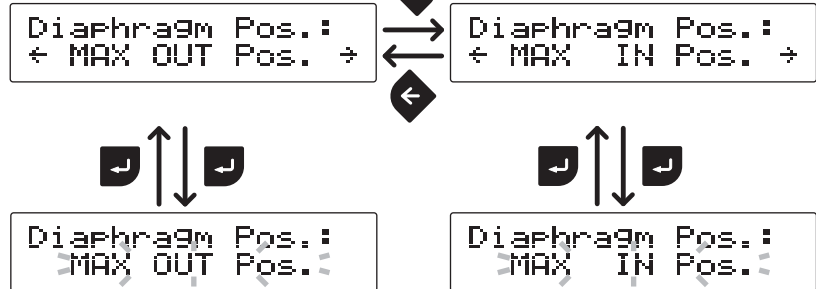

MAX OUT Pos. : The diaphragm comes to the top dead point.
MAX IN Pos. : The diaphragm comes to the bottom dead point.
Either one of the above indication keeps flashing as long as the diaphragm is at either end. See page 59 for diaphragm replacement.

Anti chattering

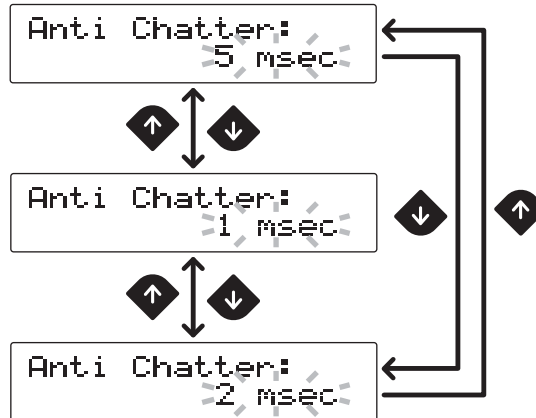

Flow rate unit

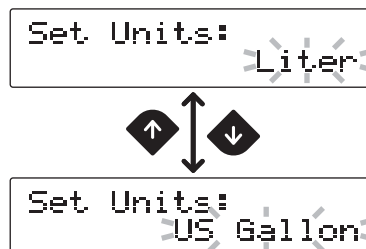

<To next page>

Language selection

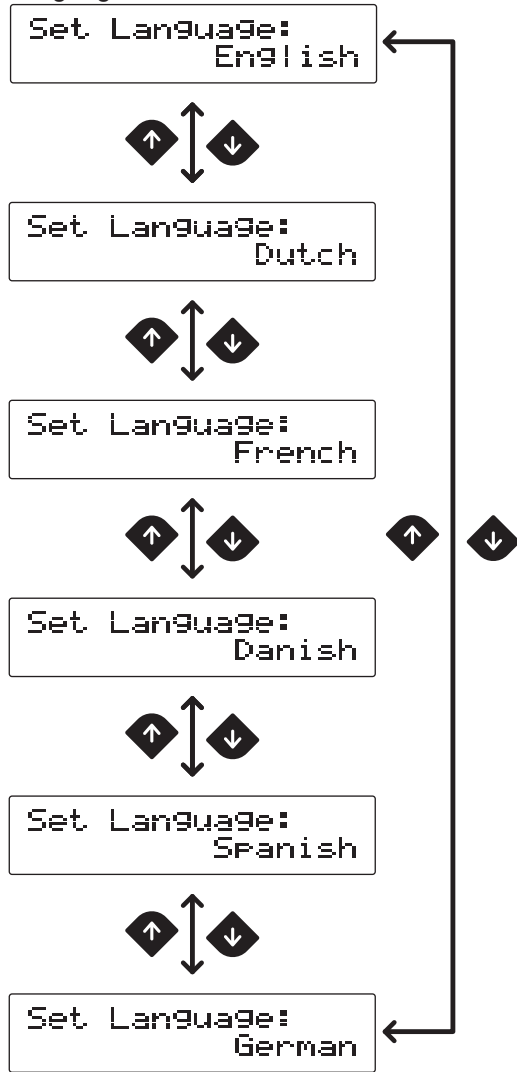

Operation

Read this section before operation.

Manual operation

Run or stop the pump by keypad operation.

- 1 Supply the rated power voltage to the pump.
The operation LED lights in red colour, and a previous mode at the last shutoff returns.
*The pump enters the MAN/EXT selection mode when turning on power with a default setting.

- 2 Push the ESC key to enter MAN/EXT selection mode.
Push the start/stop key to stop operation if the IX is running.

```
SELECT OPERATION  
MAN ← → EXT (ANALG)
```

- 3 Push the left key to select "MAN" and the Enter key to enter that choice.
The pump enters a waiting state. Use the UP and DOWN keys to set a flow rate.

```
Standby (Manual)  
150 L/H
```

- 4 Push the start/stop key to start operation.
The operation LED lights in green colour during operation.

```
Pump On (Manual)  
150 L/H
```

EXT operation

The pump operation is controlled by the external signal.

- 1 Supply the rated power voltage to the pump.
The operation LED lights in red colour, and a previous mode at the last shutoff returns.
*The pump enters the MAN/EXT selection mode when turning on power with a default setting.

- 2 Push the ESC key to enter MAN/EXT selection mode.
Push the start/stop key to stop operation if the IX is running.

```
SELECT OPERATION  
MAN ← → EXT (ANALG)
```

- 3 Push the right key to select EXT and the Enter key to enter that choice.

```
SELECT OPERATION
MAN← →EXT(ANALG)←
```



```
Standby (EXT)
Anal09
```

Waiting state display

*The pump enters Analogue, Pulse, Batch or Interval Batch mode.

- 4 Push the start/stop key to start operation. The pump runs along with operation programming and the external signal. Pushing the same key again stops operation.

```
Pump On (Anal09)
      0 mL/H
```

The operation LED turns green during operation.

AUX function

Operation at an AUX speed starts while receiving the external signal via the AUX terminal as long as the IX is running in manual mode or EXT mode. Set an AUX speed before operation. See page 47 for detail.

Priming function

This key operation runs the pump at the maximum stroke rate in operation.

- 1 Press and hold both the UP and DOWN keys.

The pump runs at the maximum stroke rate while both the keys are pressed.

*This function is available at any time except when the pump is in the MAN/EXT selection or menu screen.

```
PRIMING OVERRIDE
      @ 150 L/H
```

Keypad lock

Keypad lock can be active for the prevention of erroneous key operation.

NOTE

- Any key operation is not acceptable when the keypad lock is active. In an emergency, pressing the start/stop key for two seconds, the pump enters a wait state and stops running. Release this state to resume operation.
 - This function is available in MAN/EXT selection, a wait state or operation.
-

■ Keypad lock activation

- 1 Press and hold both the right and left keys for 3 seconds.

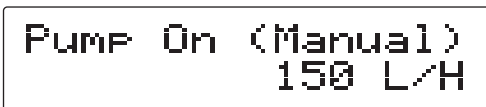

PUMP On (Manual)
150 L/H



KEY LOCKED!

"KEY LOCKED!" appears on the screen for one second.

*This indication comes up every time any key is pushed.

■ Keypad lock release

- 1 Press and hold the ESC key for 2 seconds.

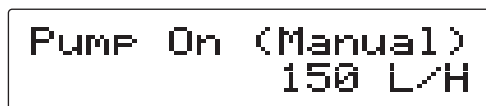

PUMP On (Manual)
150 L/H



KEY UNLOCKED!

"KEY LOCKED!" first appears on the screen and then changes to "KEY UNLOCKED!".

■ Emergency stop

- 1 Press and hold the start/stop key for 2 seconds to stop the pump.
Release the keypad lock state to resume operation.
-

Maintenance

This section describes troubleshooting, maintenance, wear part replacement, exploded views and specifications.

! Points to be observed

Observe the following points during maintenance work.

- Observe instructions in this manual for maintenance, inspection, dismantlement and assembly. Do not dismantle the pump beyond the extent of the instructions.
- Always wear protective clothing such as an eye protection, chemical resistant gloves, a mask and a work cap during dismantlement, assembly or maintenance work.
- Be sure to turn off power to stop the pump and related devices before work. See below.

Before unplugging the pump

Always stop the pump by key operation. And wait for three seconds before unplugging the pump. Otherwise, the last key operation to stop the pump may not be put in memory. In this case the pump unintentionally starts to run as powered on, discharging liquid.

NOTE

- We do not assure material suitability in specified application and are not responsible for any failure due to corrosion or erosion.
- Contact your distributor or a manufacturer of the host machine which our product is built in for repair.
- Be sure to drain chemicals and clean the inside of the pump before return so that a harmful chemical does not spill out in transit.

Troubleshooting

First check the following points. If the following measures do not help remove problems, contact your nearest distributor.

■ Pump

States	Possible causes	Solutions
The pump does not run (The operation LED does not light or the screen is blank.).	Power voltage is too low.	• Observe the allowable voltage range of 90-264VAC
	The pump is not powered.	• Check the pump is switched on. • Correct wiring. • Replace a breaking wire to new one.
Liquid can not be pumped up.	Air lock in the pump	• Expel air. See page 33.
	Air ingress through a suction line	• Reroute piping.
	An O ring is not fitted to a valve set.	• Fit O ring to the valve set.
	Foreign matters are stuck in the pump head valves.	• Dismantle, inspect and clean the valves. Replace as necessary.
	A ball valve is stuck on a valve seat.	• Dismantle, inspect and clean the valve. Replace as necessary.
A valve seat has been pressed in the valve guide.	• Do not push the valve seat into the valve guide. See page 59.	
A flow rate fluctuates.	Air stays in the pump head.	• Expel air. See page 33.
	Overfeeding occurs.	• Mount a back pressure valve to keep a constant level of discharge line pressure.
	Foreign matters are stuck in the pump head valves.	• Dismantle, inspect and clean the valves. Replace as necessary.
	Diaphragm is broken.	• Replace the diaphragm. See page 59.
	Pressure fluctuates at an injection point.	• Maintain a pressure constant at an injection point by optimizing piping or by relocating the point.
Liquid leaks.	A fitting is loose.	• Tighten the nut to fix the fitting.
	Loose fit of the pump head	• Retighten the pump head. See page 32.
	An O ring is not fitted to a valve set.	• Fit O ring to the valve set. See page 58.
	Diaphragm is broken. A leak from the drain port (Vent hole)	• Replace the diaphragm. See page 59.

Error messages

Take measures below when error messages appear during operation. Contact us or your nearest distributor as necessary.

Error messages	Possible causes	Measures
MOTOR OVERLOAD! S/S Key = Clear	Pressure overload protection is active.	<ul style="list-style-type: none"> Check a discharge line for clogging and remove it as necessary. If this error happens during the transfer of high viscosity liquid, make a discharge line bore wider and its length shorter.
LEAK DETECTED! S/S Key = Clear	Diaphragm is broken.	<ul style="list-style-type: none"> Replace the broken diaphragm with new one. See page 59 for detail.
DRIVE ERROR! S/S Key = Clear	Sensor failure	<ul style="list-style-type: none"> A sensor in the drive unit has failed. Contact us or your nearest distributor.

Inspection

Perform daily and periodic inspection to keep pump performance and safety.

Daily inspection

Check the following points. Upon sensing abnormality, stop operation immediately and remove problems according to "Troubleshooting".

When wear parts come to the life limit, replace them by new ones. Contact your distributor for detail.

No.	States	Points to be checked	How to check
1	Pumping	• If liquid is pumped.	Flow meter, pressure gauge or visual inspection
		• If discharge pressure is normal.	Pressure gauge
		• If liquid is deteriorated, crystallized or settled.	Visual or audio inspection
2	Noise and vibration	• If abnormal noise or vibration occurs. They are signs of abnormal operation.	Visual or audio inspection
3	Air ingress from pump head joints and a suction line	<ul style="list-style-type: none"> If leakage occurs. If pumped liquid includes air bubbles, check lines for leakage and retighten as necessary. 	Visual or audio inspection

Periodic inspection

Retighten the pump head mounting bolts evenly to the following torque in diagonal order.

*Mounting bolts may loosen in operation. How fast the bolts start to loosen is depending on operating conditions.

Tightening torque

Model code	Torque	Bolts	Number of bolts
IX-C150	12 N•m	M8 hexagon head bolt	8
IX-C060	3.5 N•m	M5 hexagon head bolt	6

Wear part replacement

To run the pump for a long period, wear parts need to be replaced periodically. It is recommended that the following parts are always stocked for immediate replacement. Contact your nearest distributor for detail.

! Precautions

- When dismantling the pump, pay attention to the residual liquid in the pump head.
- Rinse wet ends thoroughly with tap water.
- Each time the pump head is dismantled, replace the diaphragm and the valve sets with new ones.

Wear part list

Pump head	Parts	# of parts	Estimated life
C150	Valve set (TC type) Discharge side IX0021 Suction side IX0022 	2 sets	8000 hours
	Valve set (TE type) Discharge side IX0034 Suction side IX0033 	2 sets	8000 hours
	Valve set (S6 type) IX0032 	2 sets	8000 hours
	Diaphragm 	1	4000 hours

Pump head		Parts	# of parts	Estimated life
C150	Retainer	<p>31 (IX0015)</p>	1	8000 hours
C060	Valve set (TC type) IX0069	<p>7 (IX0051)</p> <p>3 (IX0048)</p> <p>2 (IX0047)</p> <p>4 (IX0049)</p> <p>7 (IX0051)</p> <p>9 (IX0053)</p> <p>7 (IX0051)</p>	2 sets	8000 hours
	Valve set (TE type) IX0070	<p>7 (IX0052)</p> <p>3 (IX0048)</p> <p>2 (IX0047)</p> <p>4 (IX0050)</p> <p>7 (IX0052)</p> <p>9 (IX0053)</p> <p>7 (IX0052)</p>	2 sets	8000 hours
	Valve set (S6 type) IX0082	<p>10 (IX0075)</p> <p>3 (IX0073)</p> <p>2 (IX0072)</p> <p>10 (IX0075)</p> <p>4 (IX0074)</p> <p>10 (IX0075)</p>	2 sets	8000 hours
	Diaphragm	<p>30 (IX0061)</p>	1	4000 hours
	Retainer	<p>31 (IX0062)</p>	1	8000 hours

*Wear part duration varies with the pressure, temperature and characteristics of liquid.
 *The estimated life is calculated based on pumping clean water at ambient temperature.
 *Parenthetic codes are selection codes.

Before replacement

1 Stop pump operation.

2 Close the suction line.

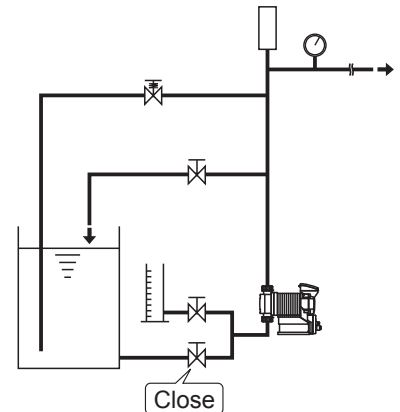

3 Open the drain valve to release liquid out of the discharge line.

NOTE

Open the valve gradually. Chemicals may be purged if the discharge line pressure maintains higher pressure than atmospheric pressure.

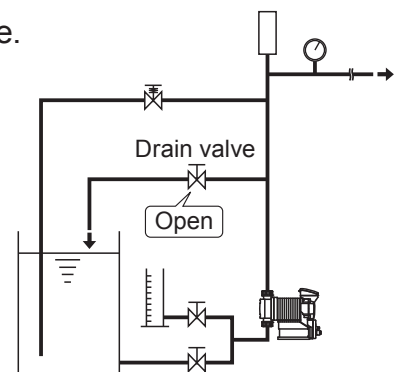

Valve set replacement

1 Remove pipes from the pump.

NOTE

- Be careful not to get wet with residual chemicals in piping.
- Rinse off chemicals or crystals as necessary.
- The valve set may come down as the suction pipe is removed. Take care not to drop it.
- Remove the IX-C060 TC/TE nuts while holding the adapter with a spanner.

IX-C150 TC/TE

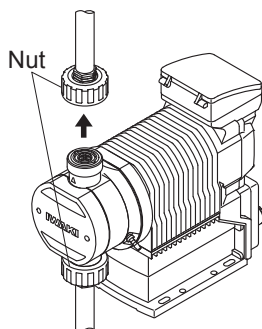

IX-C060 TC/TE

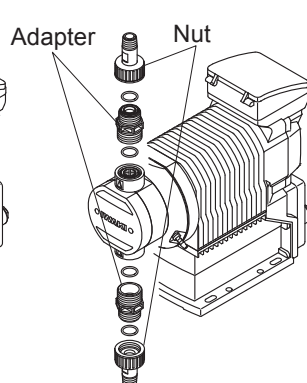

IX-C150 S6

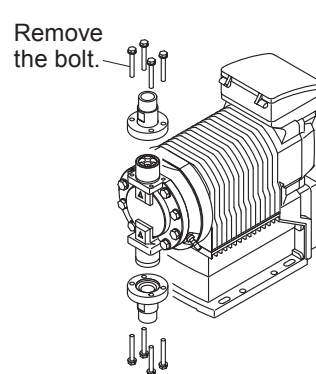

IX-C060 S6

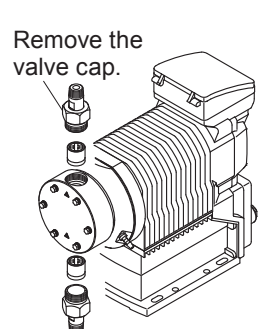

- 2 Take out valve sets from the pump head.
Clean the pump head as necessary.

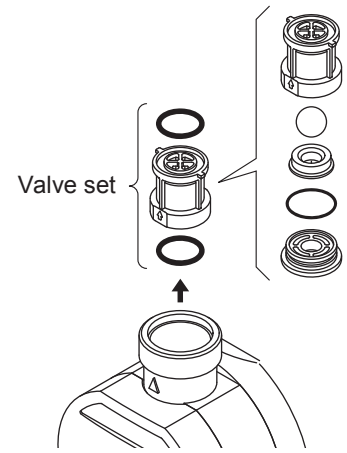

- 3 Take apart valve sets and replace wear parts with new ones as necessary. Reassemble and remount the valve sets in the pump head.

Observe the mounting order and direction of valve set components. See the exploded view at each model.

NOTE

- Observe the mounting direction of the valve set.
- The valve seat must be held in the valve guide by the seat holder when assembling an IX-060 TC/TE valve set. Do not push the valve seat down into the valve guide. Otherwise, a leak may result.

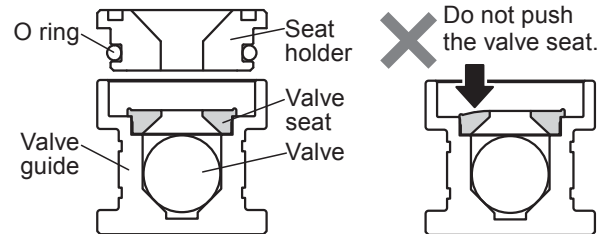

- 4 Connect pipes and the pump.

For the IX-C060 TC/TE type, tighten the adapters (16) to 4.4N•m. Excessive force may break the plastic parts.

Diaphragm replacement

Necessary tools

- 3mm hexagon wrench
- Spanner (13mm for C150/ 8mm for C060)
- Torque wrench

- 1 Remove pipes from the pump.

NOTE

- The valve set may come down as the suction pipe is removed. Take care not to drop it.
- Be careful not to get wet with residual chemicals in the pump head or the discharge pipe.

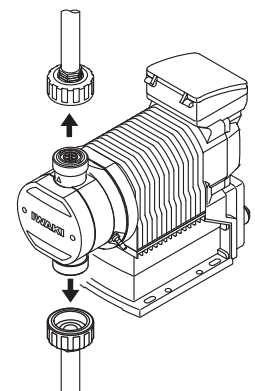

2 Remove the bolt cover by a 3mm hexagon wrench (TC/TE types).

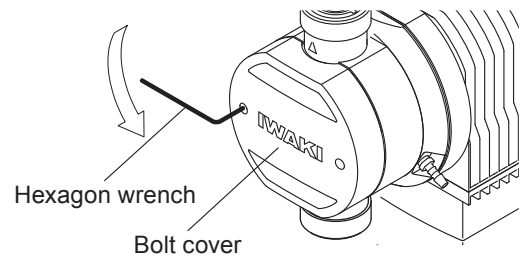

3 Use a 13mm or a 8mm spanner to remove the pump head fixing bolts (eight M8 bolts for the C150/ six M5 bolts for C060) and detach the pump head with a reinforcing plate.

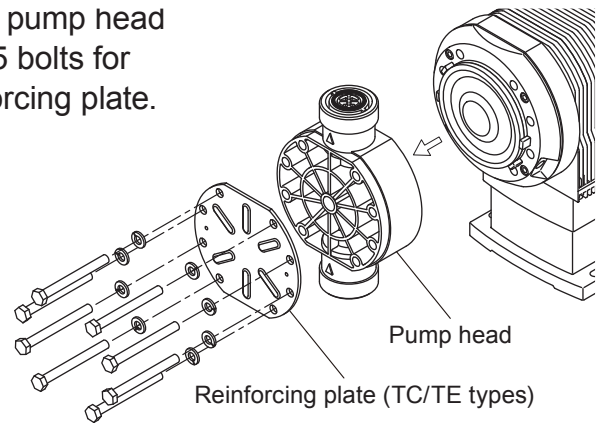

4 Extend the pump shaft by keypad operation.

Other Features:
←Diaphragm Pos.→

Select "Diaphragm Pos." through the menu screen and push the Enter key. See page 47 for detail.



Diaphragm Pos. :
← MAX OUT Pos. →

Select "MAX OUT Pos." by the right and left keys and push the Enter key.



Diaphragm Pos. :
MAX OUT Pos.

The diaphragm extends to the maximum and "MAX OUT Pos." blinks on the screen.

5 Rotate and remove the diaphragm and the retainer.

NOTE _____
Be careful not to be scratched by the pump head holders.

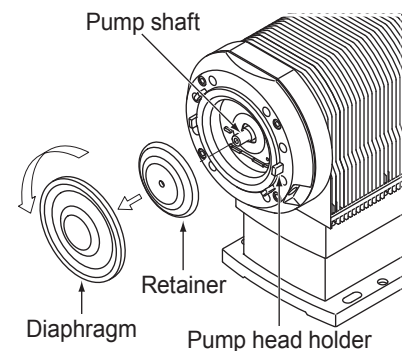

6 Clean the retainer or replace it with a new one. Apply grease (Dow Corning Toray MO-LYKOTE® HP-500) on its surface and screw burning protective agent to the shaft of a new diaphragm.

7 Fit a new diaphragm and the retainer into the pump shaft.
Slide the retainer, dome end first, onto the diaphragm shaft. And then screw the shaft into the pump shaft and tighten it until bottoms out and will not turn further.

NOTE
If it is fitted loose, failure may result.

8 Retract the pump shaft by keypad operation.

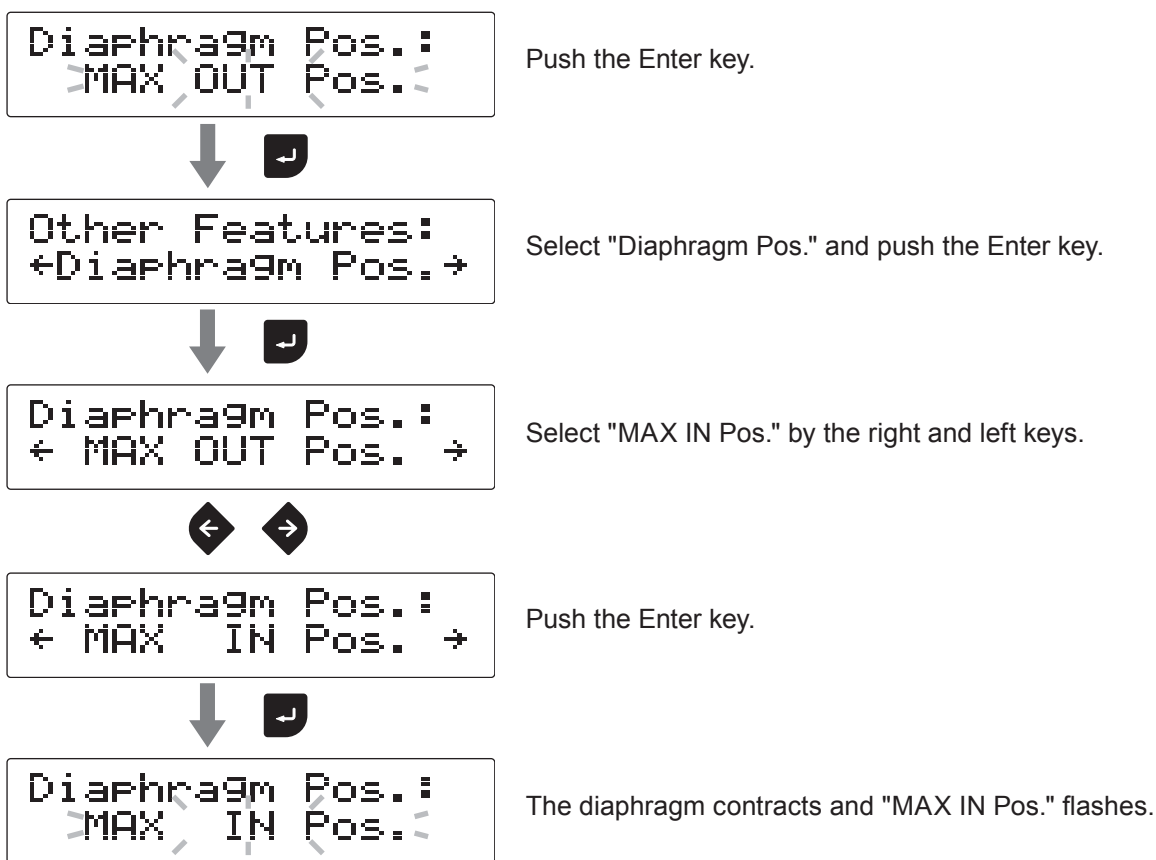

9 Mount the pump head.
Tighten the bolts evenly to 12N•m for the C150 or 3.5N•m for the C060 in diagonal order.

NOTE
Check the pump shaft has contracted to the full before mounting the pump head, or a leak or damage may result.

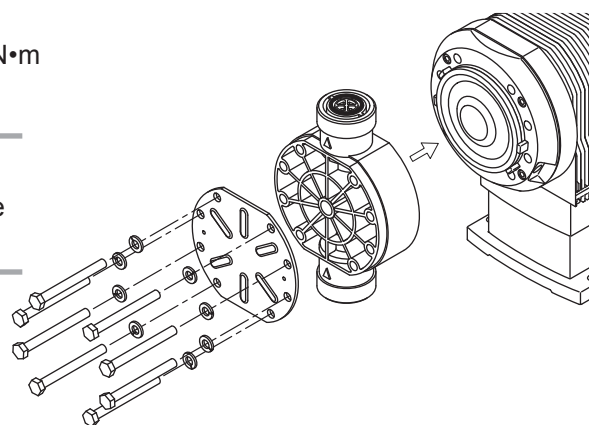

10 Fix the bolt cover by the hexagon wrench (TC/TE types).

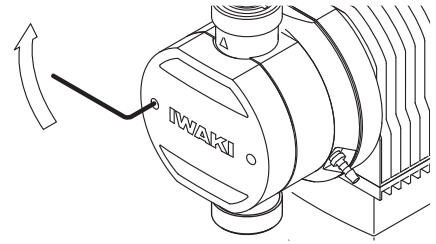

11 Connect pipes to the fittings and then tighten the nuts.

NOTE

Check if the valve set mounting direction is correct. Both the valve sets must be oriented to the same direction.

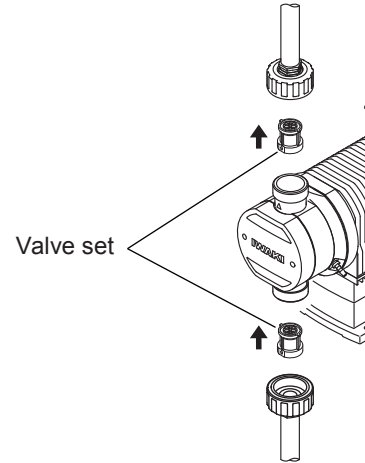

12 Go back to the waiting state.

Other Features:
+Diaphragm Pos.+

Push the Enter key once to shift to the right display.



SELECT OPERATION
MAN ← → EXT (ANALG)

Push the start/stop key to return to the MAN/EXT selection.

Exploded view

Pump head, Drive unit & Control unit

Do not dismantle the pump beyond the extent shown in the diagram below.

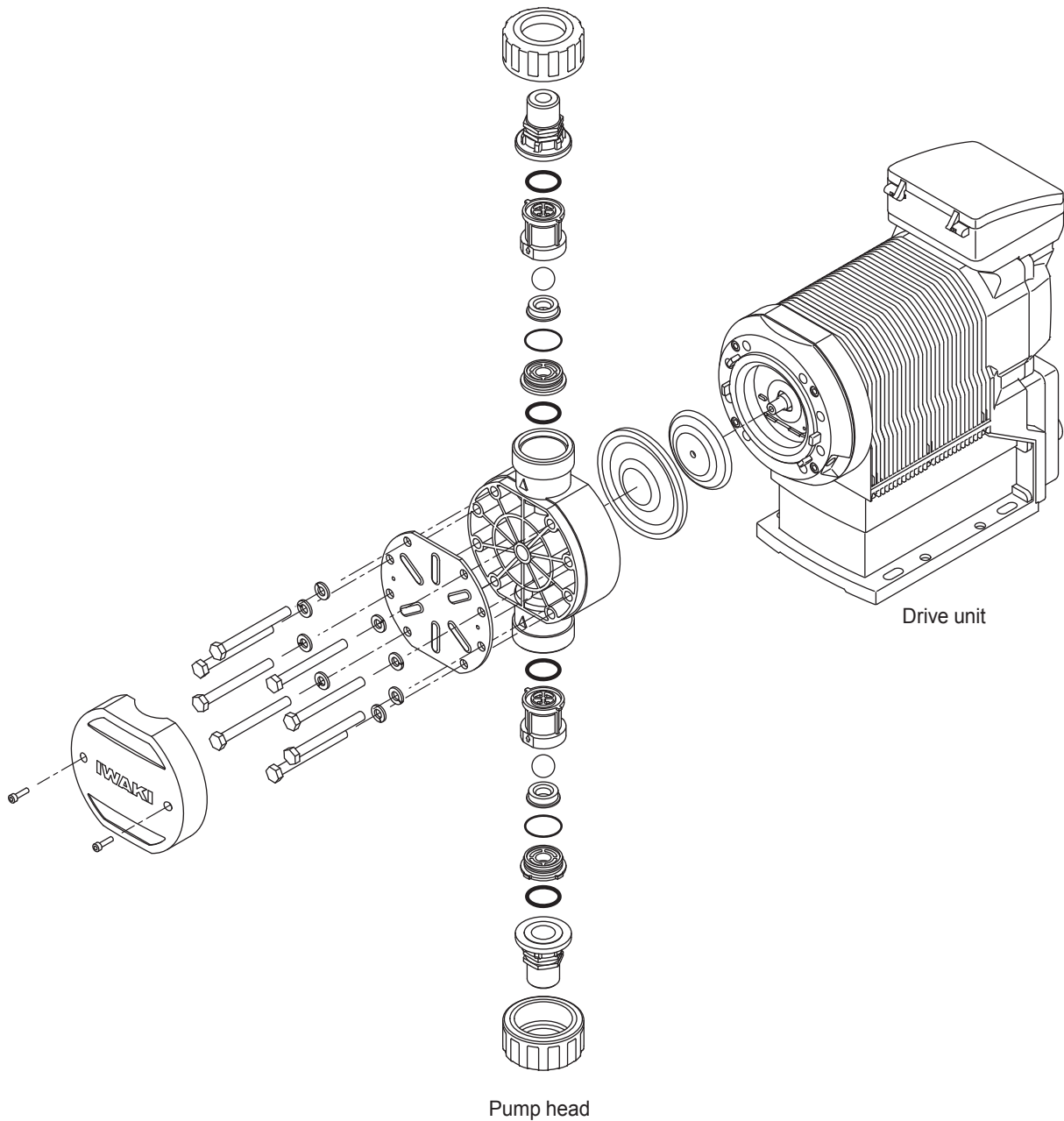

*Pump head material and size differ with models.

Pump head

■ IX-C150 TC N

No.	Part names	# of parts
1	Pump head	1
2	Valve	2
3	Valve guide	2
4	Valve seat	2
5	Out seat holder	1
6	In seat holder	1
7	O ring	4
8	O ring	2
19	Hex socket head bolt	2
20	Hexagon head bolt	8
21	Spring washer	8
28	Bolt cover	1
29	Reinforcing plate	1
30	Diaphragm	1
31	Retainer plate	1
50	Nut	2
73	Fitting	2

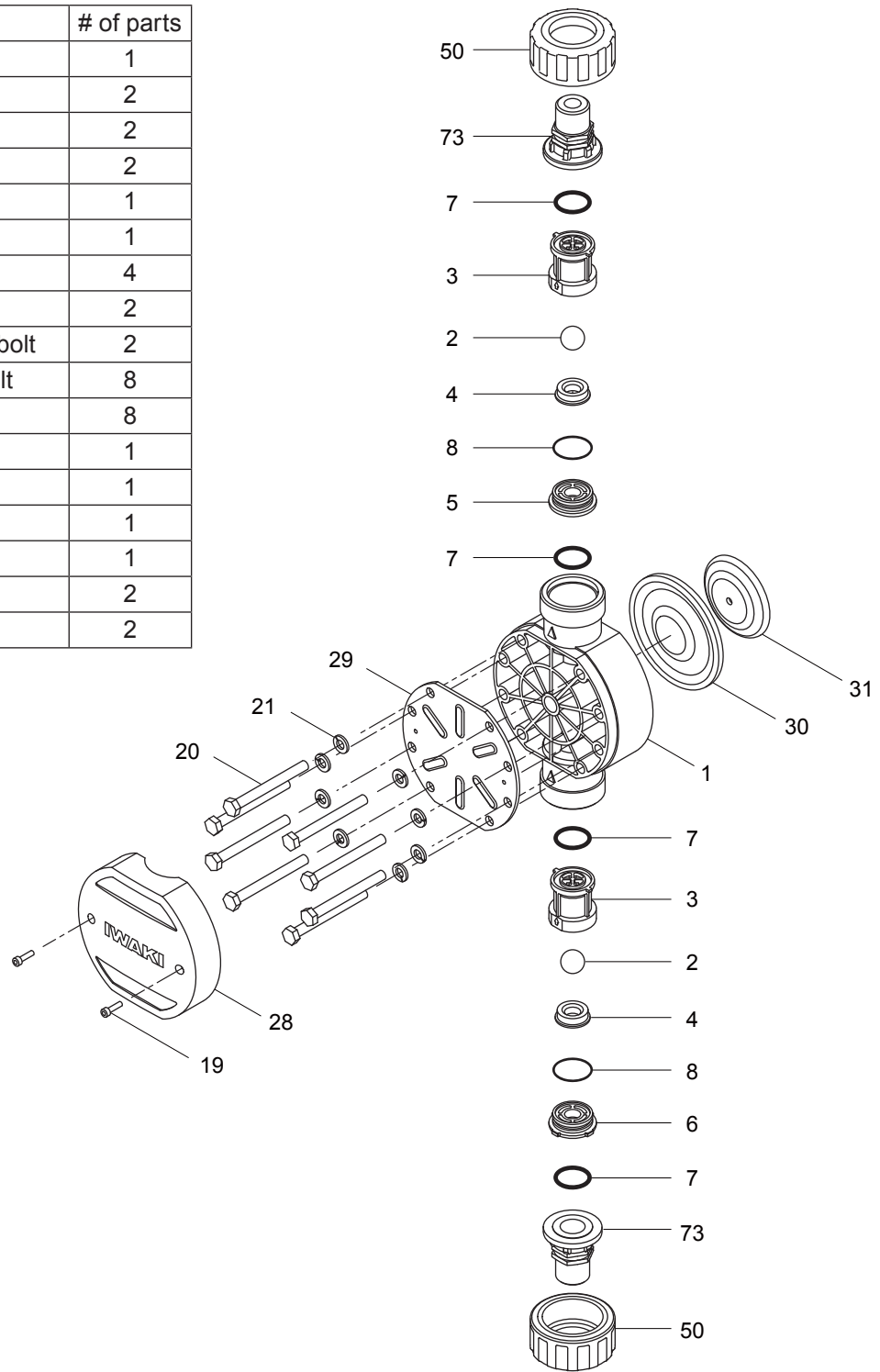

■ IX-C150 TC FA

No.	Part names	# of parts
1	Pump head	1
2	Valve	2
3	Valve guide	2
4	Valve seat	2
5	Out seat holder	1
6	In seat holder	1
7	O ring	4
8	O ring	2
19	Hex socket head bolt	2
20	Hexagon head bolt	8
21	Spring washer	8
28	Bolt cover	1
29	Reinforcing plate	1
30	Diaphragm	1
31	Retainer plate	1
45	Flange unit	2

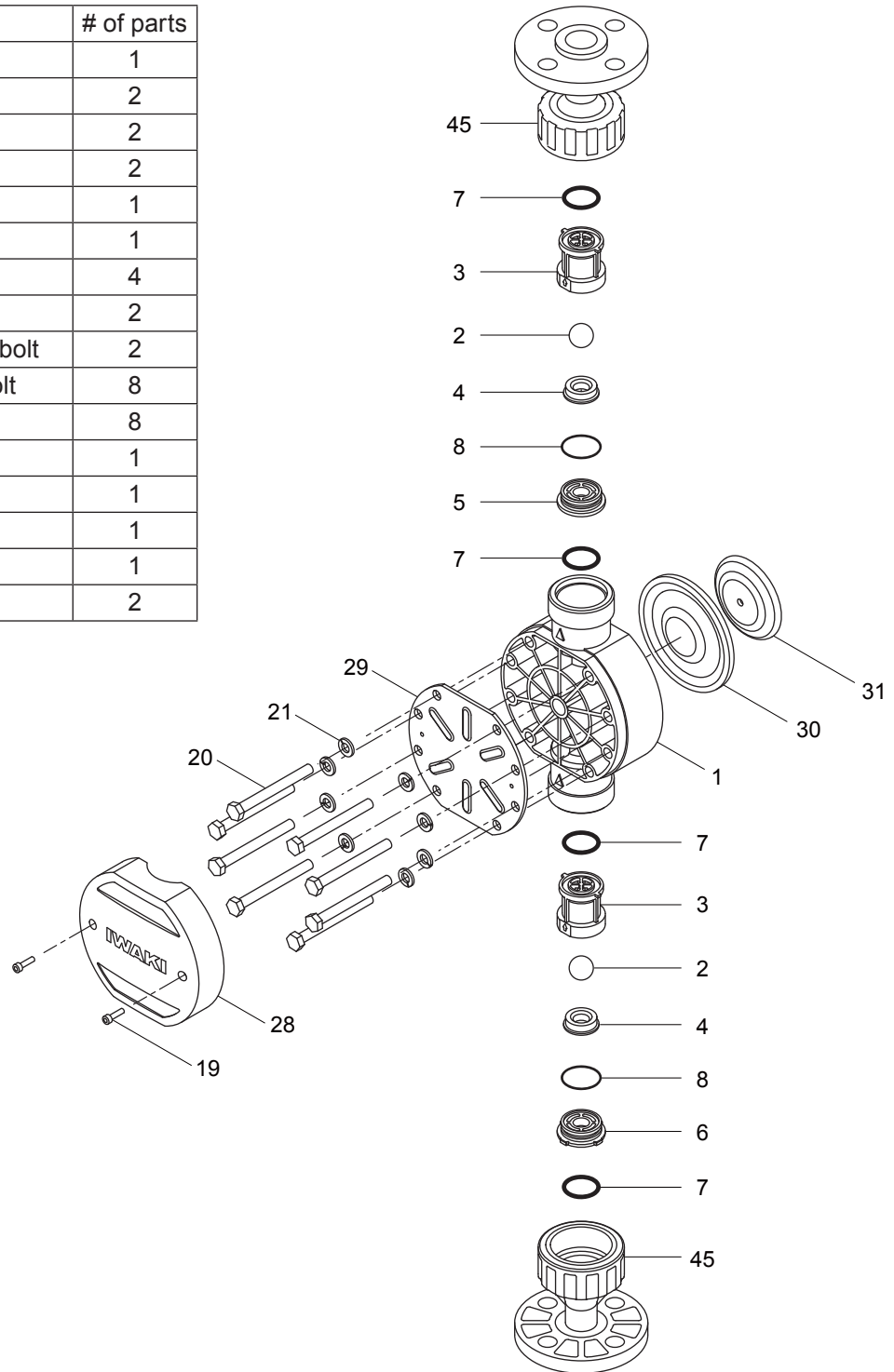

■ IX-C150 S6 N

No.	Part names	# of parts
1	Pump head	1
2	Valve	2
3	Valve guide	2
4	Valve seat	2
10	Valve gasket	6
20	Hexagon head bolt	8
21	Spring washer	8
30	Diaphragm	1
31	Retainer plate	1
55	Setting flange	2
73	Fitting	2
83	Hexagon head bolt	8

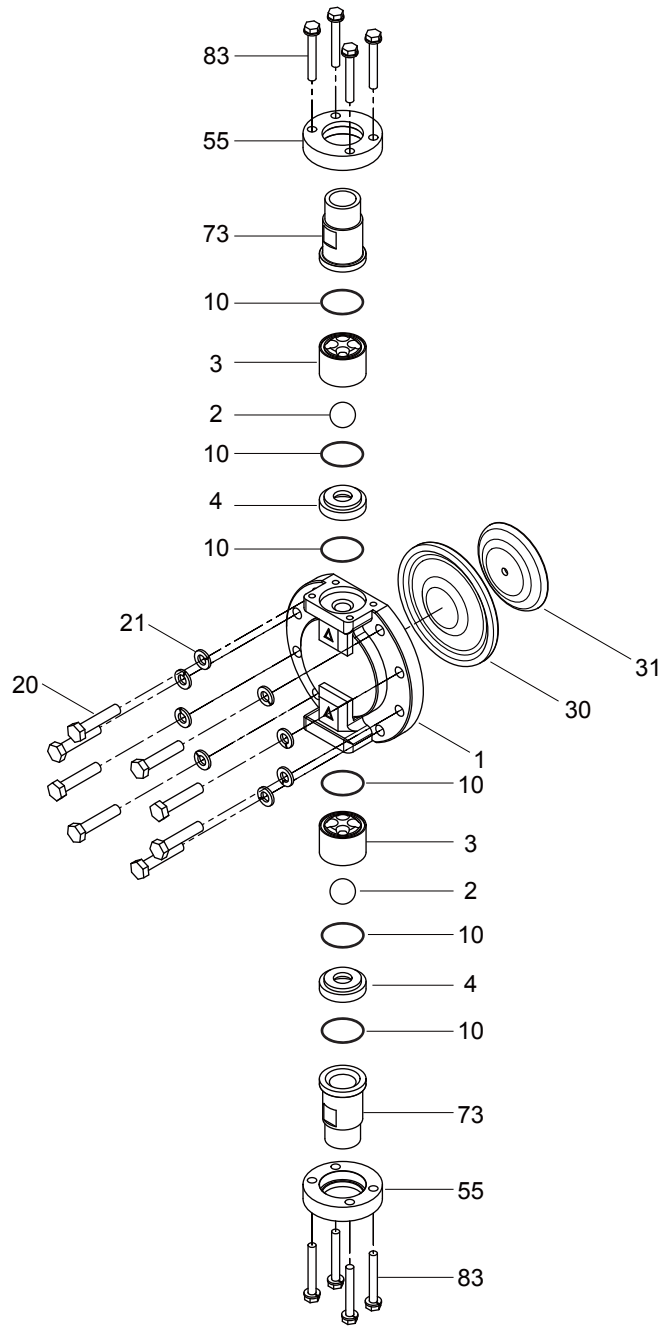

■ IX-C150 S6 FA

No.	Part names	# of parts
1	Pump head	1
2	Valve	2
3	Valve guide	2
4	Valve seat	2
10	Valve gasket	6
20	Hexagon head bolt	8
21	Spring washer	8
30	Diaphragm	1
31	Retainer plate	1
45	Flange unit	2
83	Hexagon head bolt	8

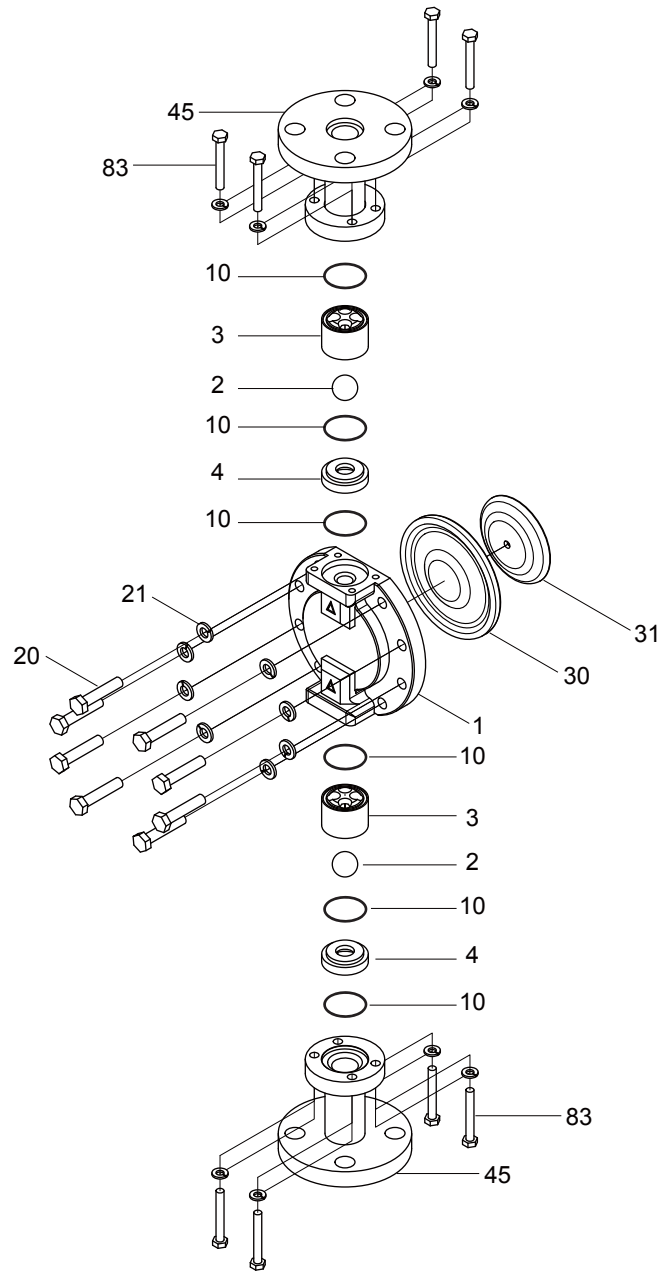

■ IX-C060 TC N

No.	Part names	# of parts
1	Pump head	1
2	Valve	2
3	Valve guide	2
4	Valve seat	2
7	O ring	8
9	Seat holder	2
16	Adapter	2
19	Hex socket head bolt	2
20	Hexagon head bolt	6
21	Spring washer	6
22	Plain washer	6
28	Bolt cover	1
29	Reinforcing plate	1
30	Diaphragm	1
31	Retainer plate	1
50	Nut	2
73	Fitting	2

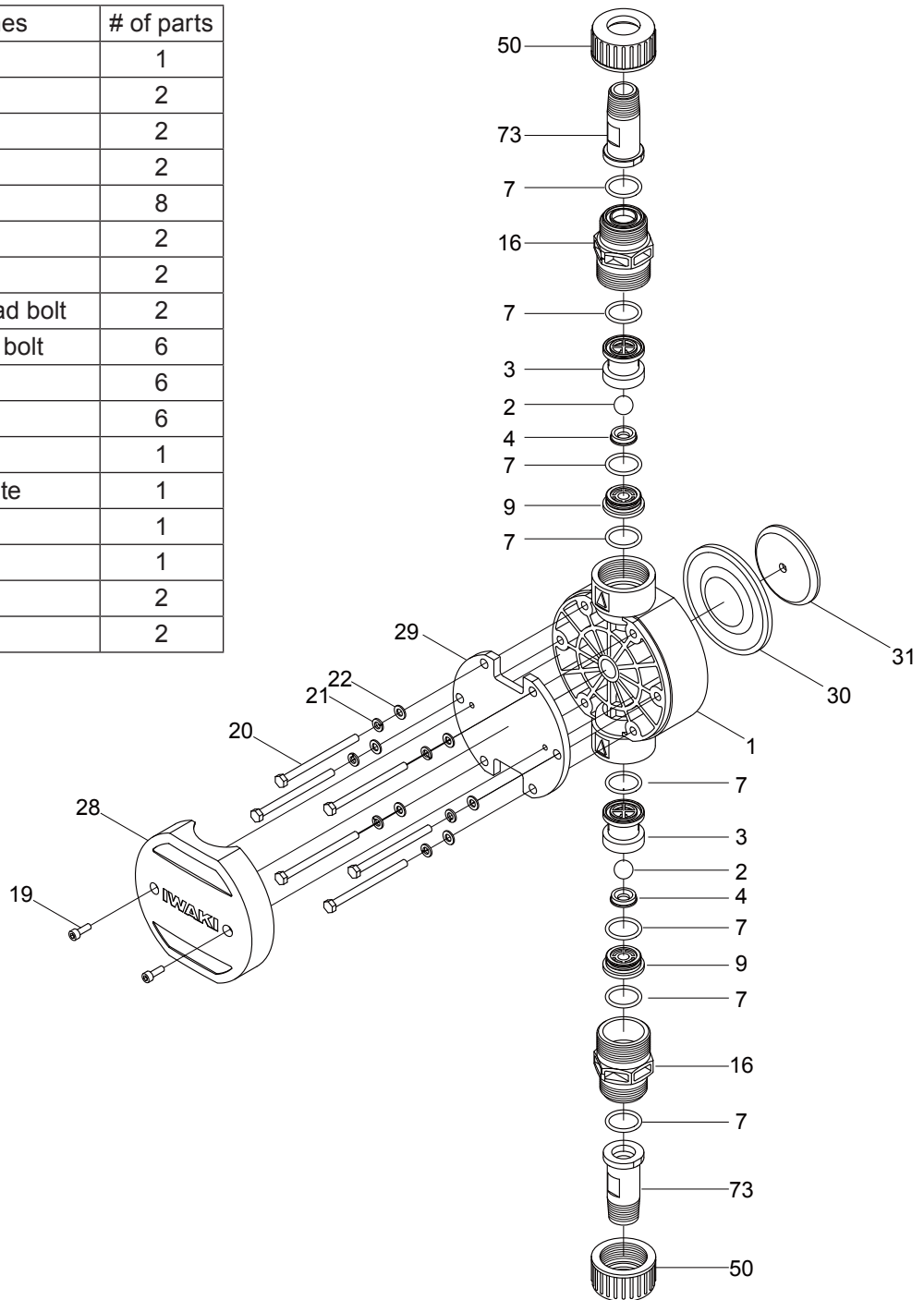

■ IX-C060 TC FA

No.	Part names	# of parts
1	Pump head	1
2	Valve	2
3	Valve guide	2
4	Valve seat	2
7	O ring	8
9	Seat holder	2
16	Adapter	2
19	Hex socket head bolt	2
20	Hexagon head bolt	6
21	Spring washer	6
22	Plain washer	6
28	Bolt cover	1
29	Reinforcing plate	1
30	Diaphragm	1
31	Retainer plate	1
45	Flange unit	2

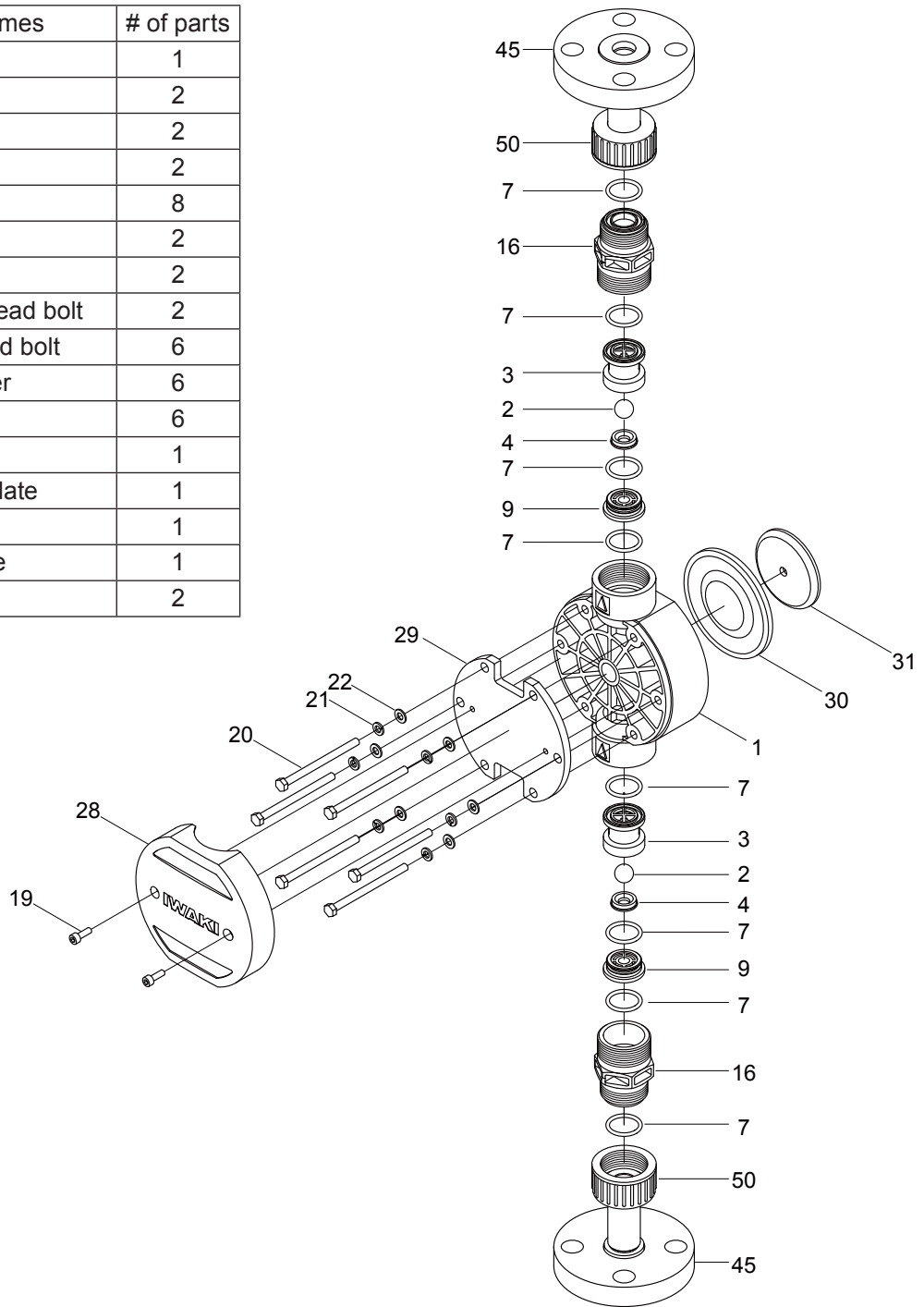

■ IX-C060 S6 N

No.	Part names	# of parts
1	Pump head	1
2	Valve	2
3	Valve guide	2
4	Valve seat	2
10	Valve gasket	6
13	Valve cap	2
20	Hexagon head bolt	6
21	Spring washer	6
22	Plain washer	6
30	Diaphragm	1
31	Retainer plate	1
73	Fitting	2

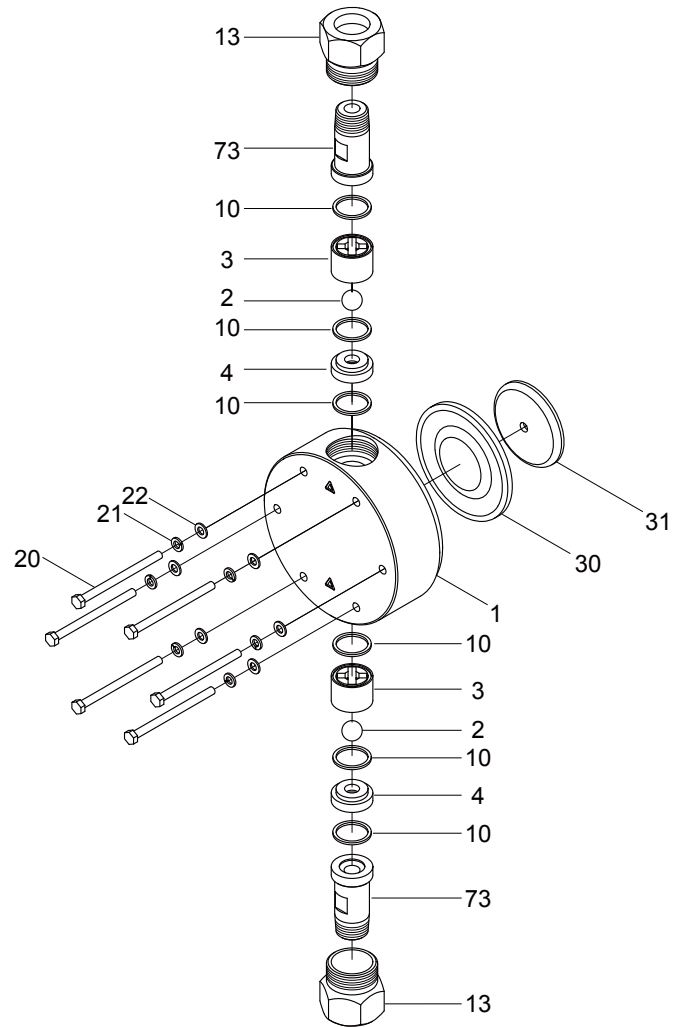

■ IX-C060 S6 FA

No.	Part names	# of parts
1	Pump head	1
2	Valve	2
3	Valve guide	2
4	Valve seat	2
10	Valve gasket	6
13	Valve cap	2
20	Hexagon head bolt	6
21	Spring washer	6
22	Plain washer	6
30	Diaphragm	1
31	Retainer plate	1
45	Flange unit	2

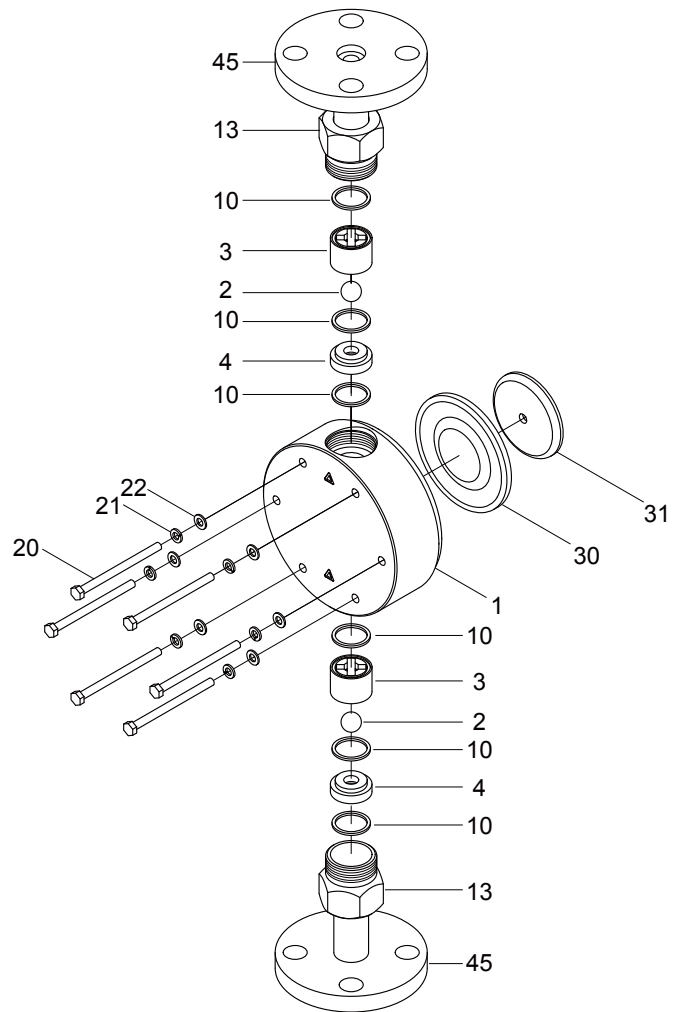

Specifications/Outer dimensions

Specifications

Information in this section is subject to change without notice.

■ Pump

Model code		Flow rate L/H (GPH)	Discharge pressure MPa (psi)	Power con- sumption W	Current value A	Connection	Weight kg				
IX-C060 TC/TE	N	0.08-60 (0.02-15.9)	1.0 (145)	62	0.8	1/2NPT	9				
	FA					ANSI 150Lb 1/2"	9				
IX-C060 S6	N					1/2NPT	11				
	FA					ANSI 150Lb 1/2"	12				
IX-C150 TC/TE	N					0.2-150 (0.05-39.6)	0.4 (58)	62	0.8	3/4NPT	9
	FA									ANSI 150Lb 3/4"	9
IX-C150 S6	N	3/4NPT	11								
	FA	ANSI 150Lb 3/4"	13								

*The above information is based on pumping clean water at rated voltage and ambient temperature.

*Pressure overload protection will stop operation when a discharge pressure has risen 1.5 to 2 times higher than the maximum level.

*Allowable room temperature: 0-50°C

*Allowable liquid temperature: 0-50°C (TC/TE), 0-80°C (S6)

*Allowable power voltage deviation: Within ±10% of the rated range

*Ambient humidity: 30-90%RH (Non condensing)

*When running the IX-C150 S6 at or below 1L/H or the IX-C060 S6 at or below 0.4L/H, an actual flow rate may not meet a target rate.

*Noise level: 70dB(A) for the TC and TE types and 80dB(A) for the S6 type.

■ Power cable

Conduction section area	18AWG Triplex cable (L/N/PE)
Length	2000 [mm]
Standard	U type : SJT W-A U2 type : SJT W
Terminal treatment	Plug

■ Body colour

Blue	Munsell colour system 7.5PB 3/8
------	---------------------------------

■ Control unit

Operation modes	MAN (Manual)	A flow rate is set with ↑ (Up) and ↓ (Down) keys.	
	EXT	Analogue control	4-20/ 0-20/ 20-4/ 20-0mA
		Pulse control	0.01560mL/PLS - 300mL/PLS (C150)
			0.00625mL/PLS - 120mL/PLS (C060)
		Batch control	15.6mL/PLS - 300L/PLS (C150)
			6.25mL/PLS - 120L/PLS (C060)
Interval batch control	0-9day, 0-23hr, 1-59min		
	15.6mL - 300L/PLS (C150) 6.25mL - 120L/PLS (C060)		
Profibus control	Profibus-DP Compliant to EN50170 (IEC61158)		
Monitors	LCD	16×2 backlit LCD	
	LED	OPERATE	Lights in green colour during pump operation.
			Lights in orange colour when a Pre-STOP signal is input.
			Lights in red colour when the pump has stopped or flashes when pressure overload is detected.
ALARM	Lights in red colour when Alarm1 or Alarm2 is activated.		
Operation	Key-pads	①(Start/Stop), MENU, ESC, ↵ (Enter), ↑ (Up), ↓ (Down), ← (Left) and → (Right) keys	
Control functions	STOP	Operation stop at contact input*1	
	PRIME	Max spm operation while the UP and DOWN keys are pressed.	
	Interlock	Operation stop at contact input*1	
	AUX	Operation at AUX speed at contact input	
Input	Stop/ Pre-STOP	No-voltage contact or open collector*2	
	AUX	No-voltage contact or open collector*2	
	Interlock	No-voltage contact or open collector*2	
	Analogue	0-20mADC (Internal resistance is 200Ω.)	
	Pulse	No-voltage contact or open collector (Max pulse frequency : 100Hz)	
Output	Alarm1	No voltage contact (Mechanical relay) 250VAC 3A (Resistive load) Enable or disable STOP, Pre-STOP, Interlock, Leak Detection and Motor Overload.	
	Alarm2	No voltage contact (PhotoMOS relay) 24VAC/DC 0.1A (Resistive load) Enable or disable STOP, Pre-STOP, Interlock, Leak Detection and Motor Overload.	
	Power supply	12VDC 30mA or below	
Power voltage*3		100-240VAC 50/60Hz	

*1 The setting can be changed to "operation resumption at contact input".

*2 The maximum applied voltage from the IX to an external contact is 12V at 5mA. When using a mechanical relay, its minimum application load should be 5mA or below.

*3 Observe the specified power voltage range. Otherwise failure may result. The allowable power voltage range is 90-264VAC.

Outer dimensions

■ IX-C060/-C150 TC/TE N-TB

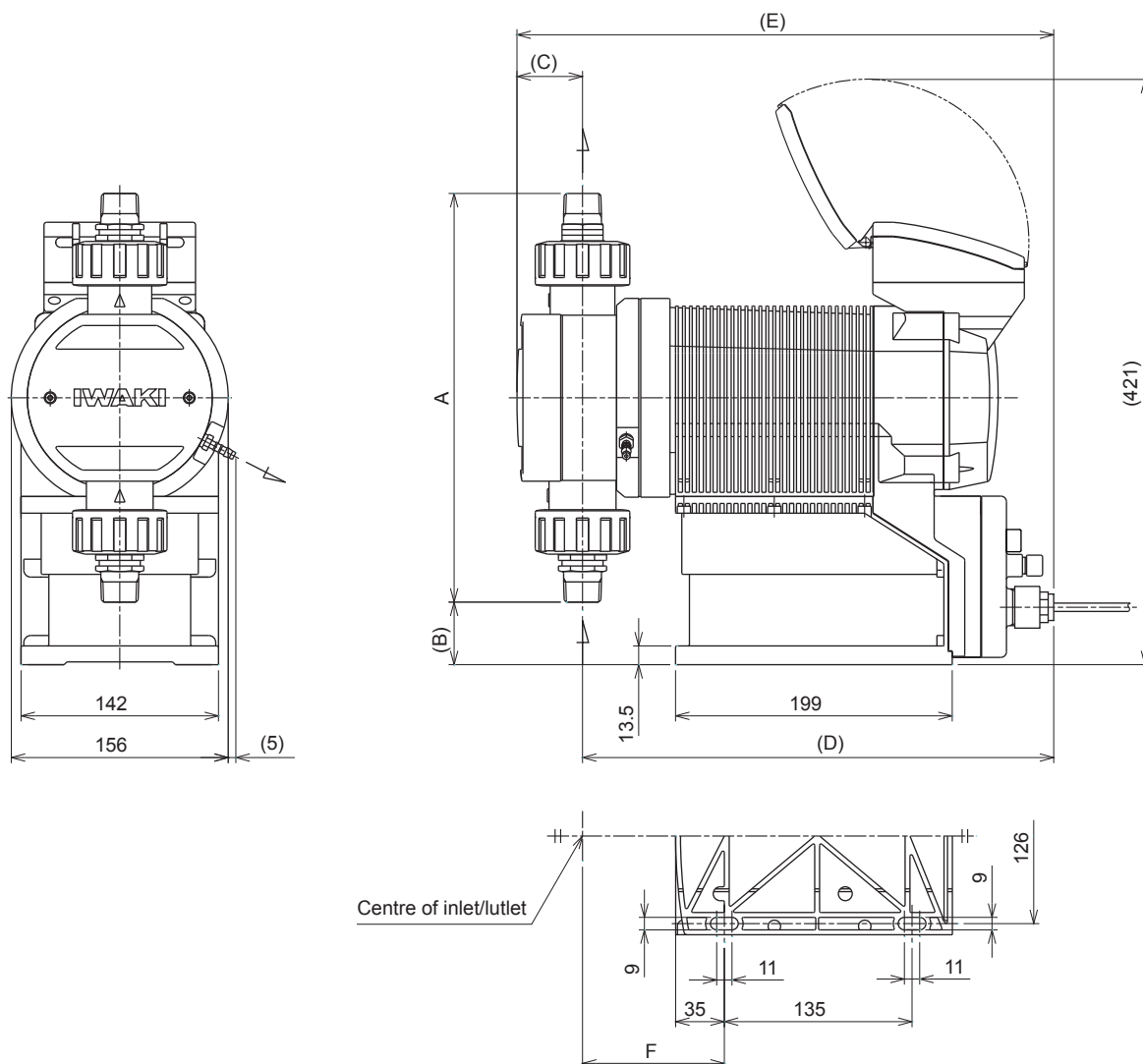

	A	B	C	D	E	F
IX-C150 TC/TE N	294	45	47	339	386	102
IX-C060 TC/TE N	325	30	35	339.5	375	102.5

■ IX-C060/-C150 TC/TE FA-TB

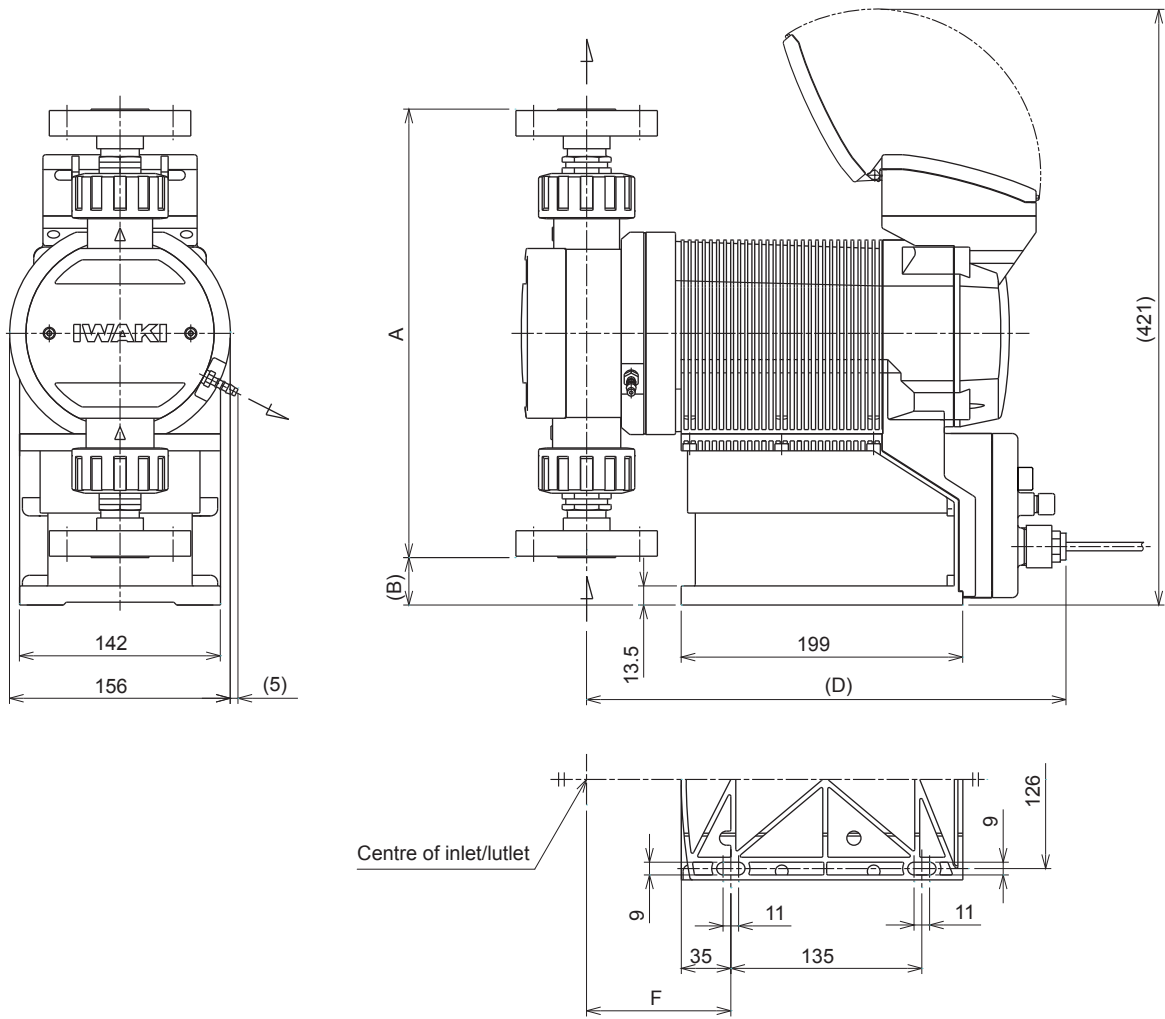

	A	B	C	D	E	F
IX-C150 TC/TE FA	317	34	—	339	—	102
IX-C060 TC/TE FA	335	25	—	339.5	—	102.5

■ IX-C060/-C150 TC/TE N-RF

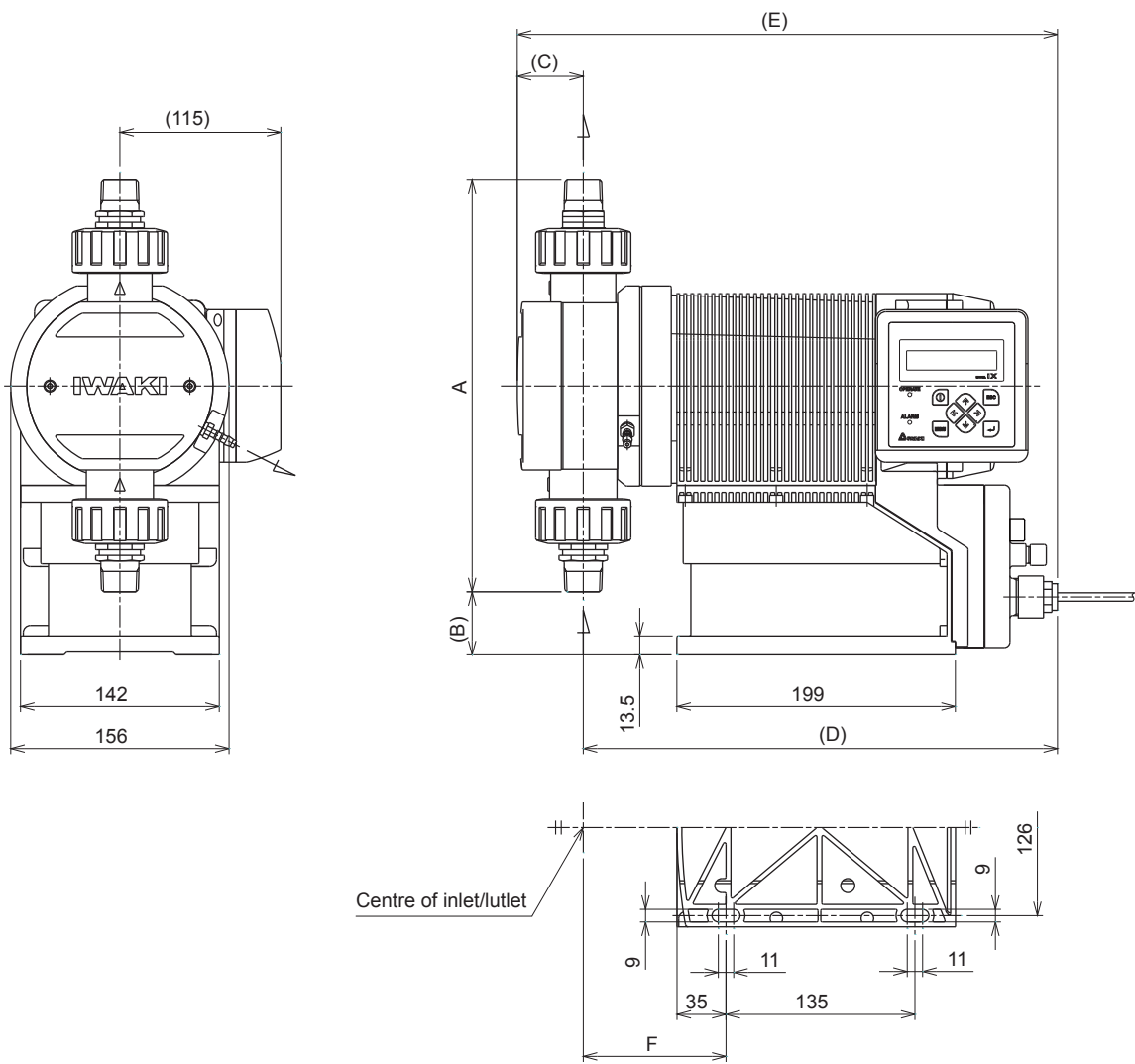

	A	B	C	D	E	F
IX-C150 TC/TE N	294	45	47	339	386	102
IX-C060 TC/TE N	325	30	35	339.5	375	102.5

■ IX-C060/-C150 TC/TE FA-RF

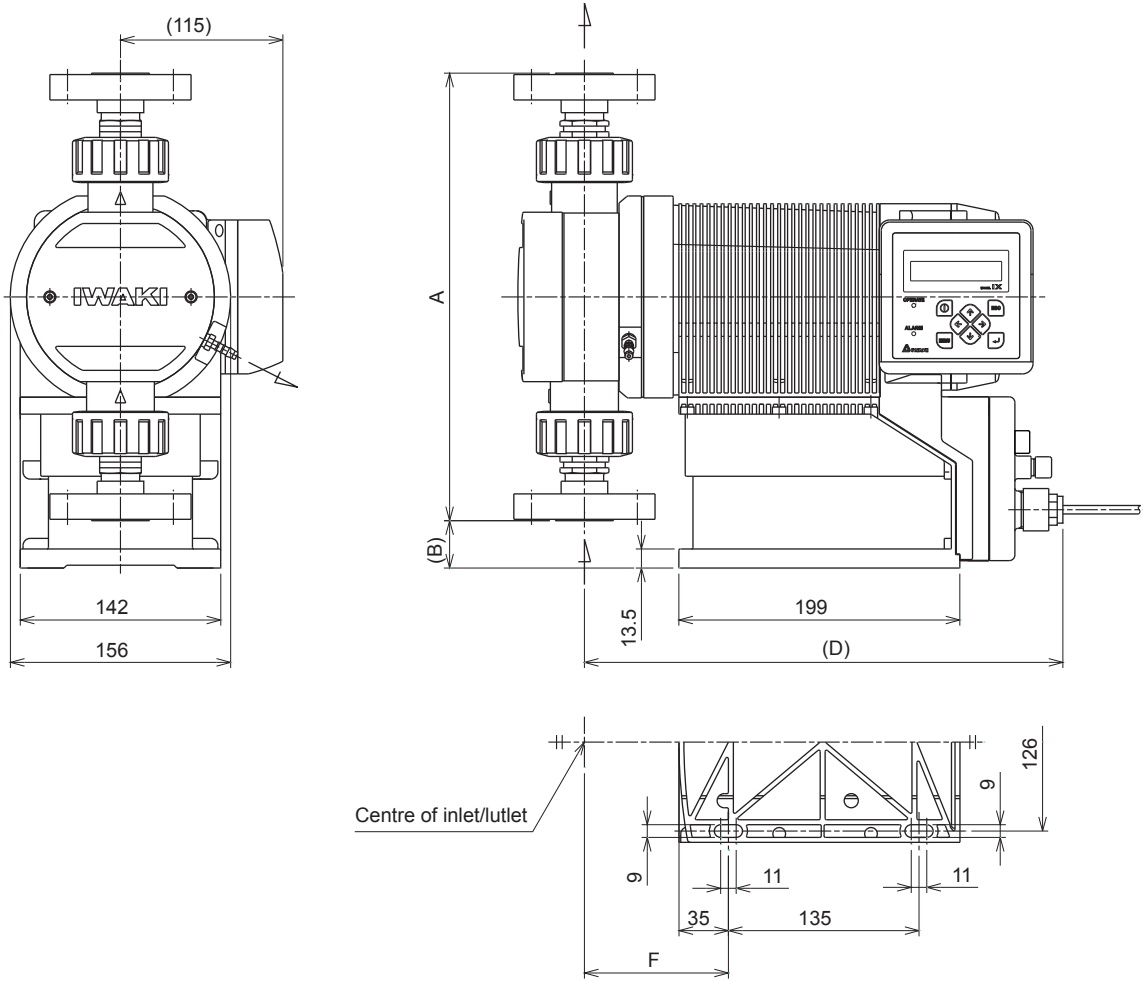

	A	B	C	D	E	F
IX-C150 TC/TE FA	317	34	—	339	—	102
IX-C060 TC/TE FA	335	25	—	339.5	—	102.5

■ IX-C060/-C150 S6 N-TB

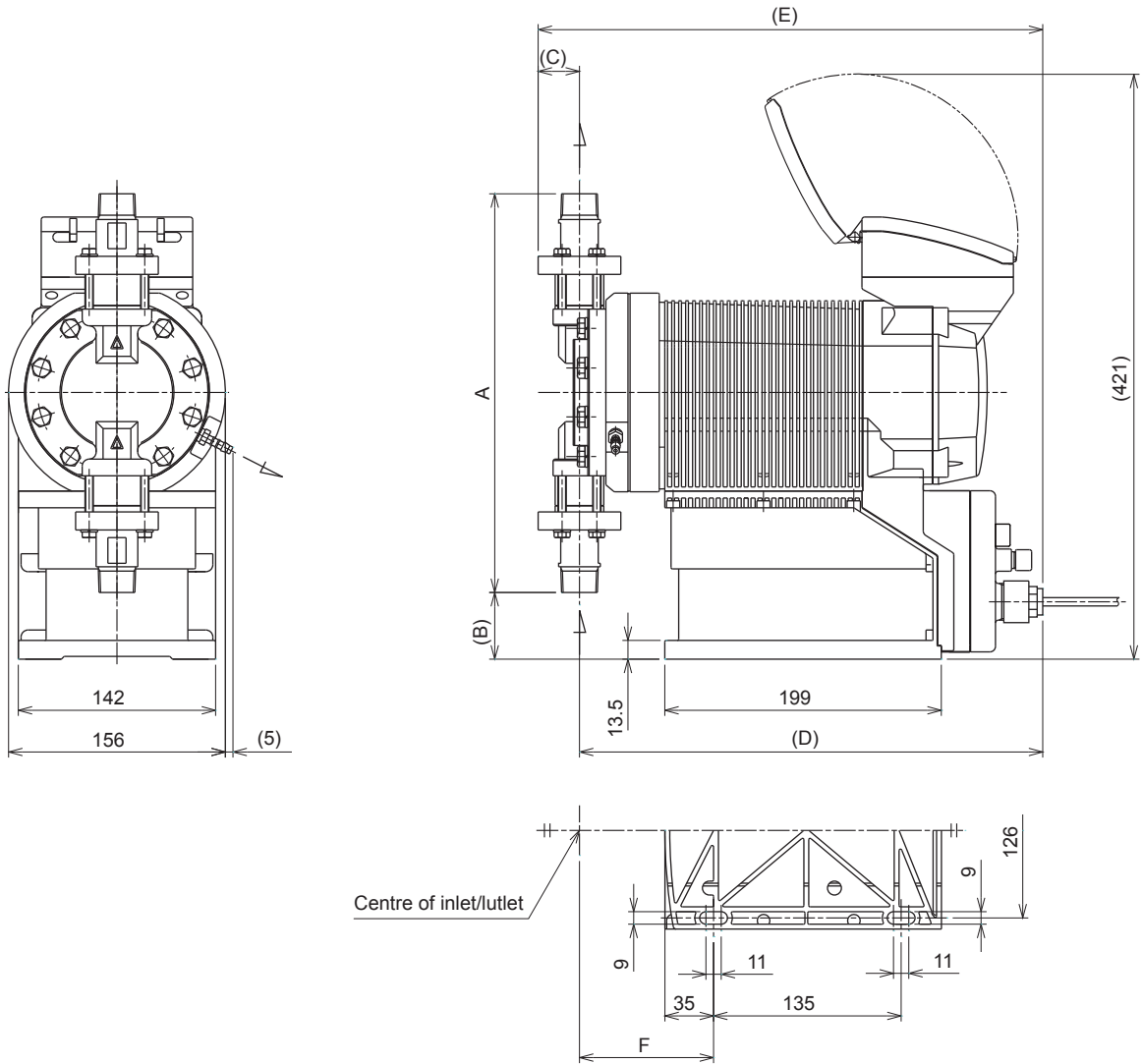

	A	B	C	D	E	F
IX-C150 S6 N	287	48	30	333.5	363	96.5
IX-C060 S6 N	240	72	25	339	364	102

■ IX-C060/-C150 S6 FA-TB

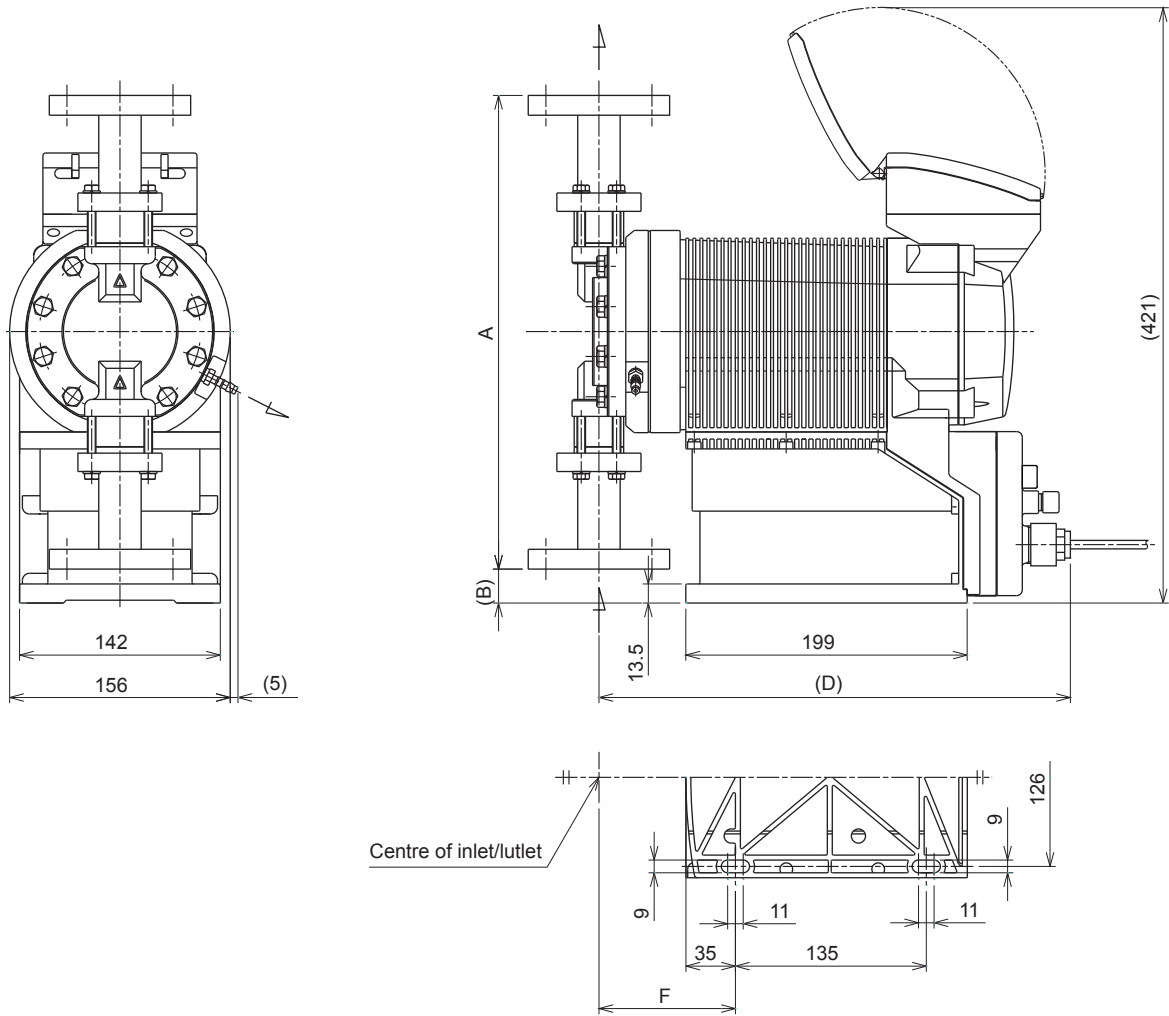

	A	B	C	D	E	F
IX-C150 S6 FA	335	24	—	333.5	—	96.5
IX-C060 S6 FA	270	57	—	339	—	102

■ IX-C060/-C150 S6 N-RF

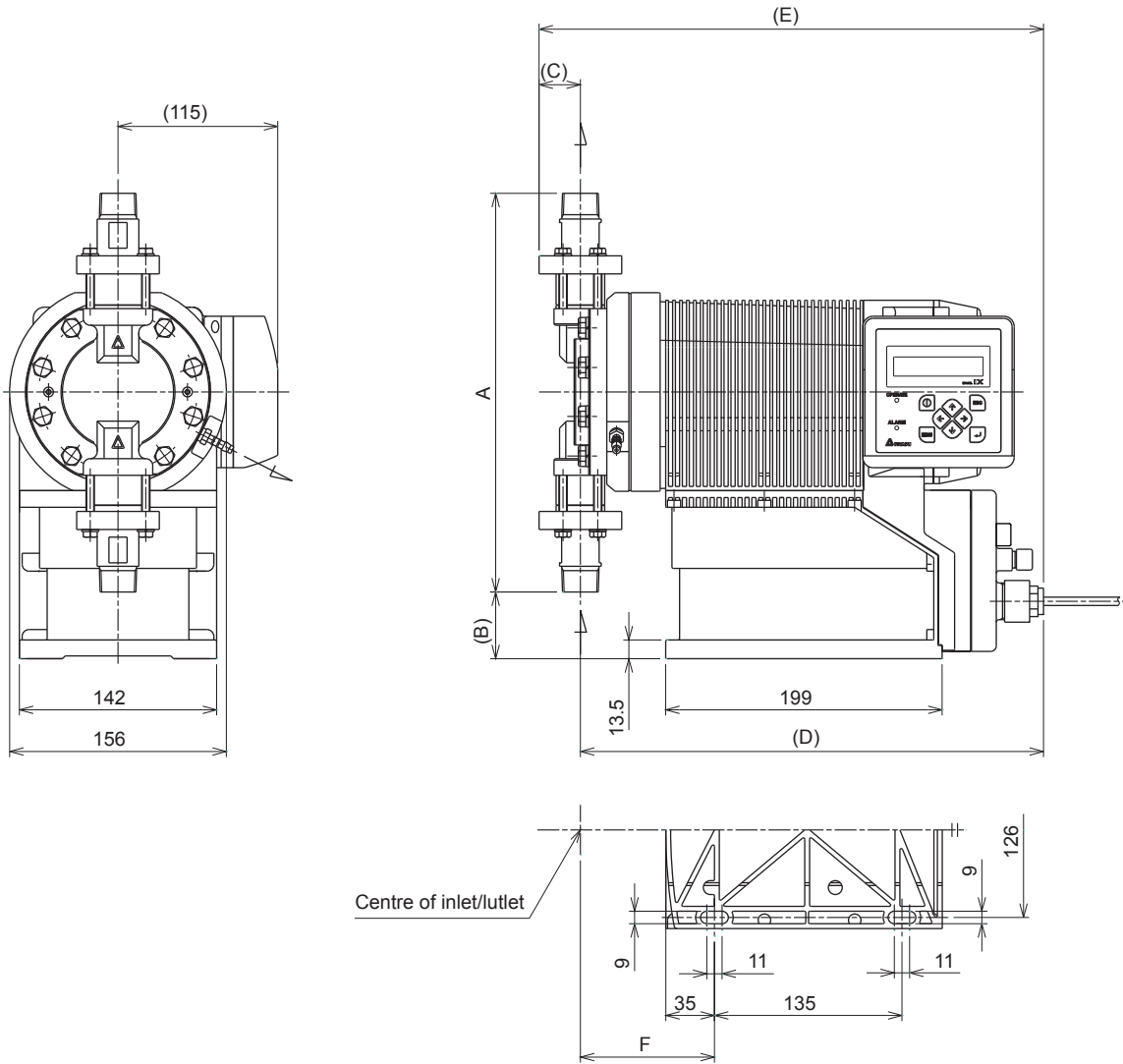

	A	B	C	D	E	F
IX-C150 S6 N	287	48	30	333.5	363	96.5
IX-C060 S6 N	240	72	25	339	364	102

■ IX-C060/-C150 S6 FA-RF

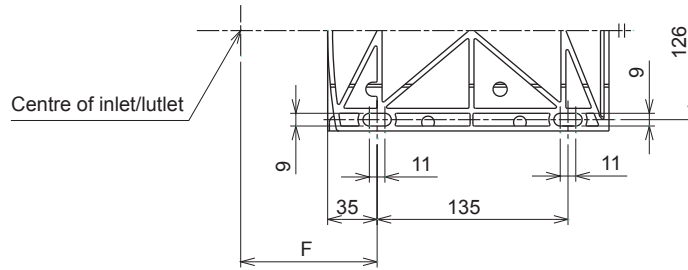
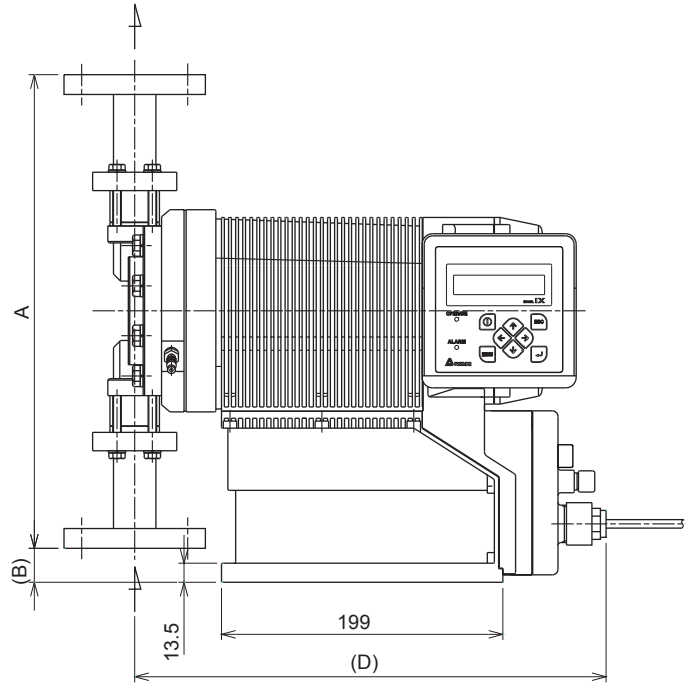
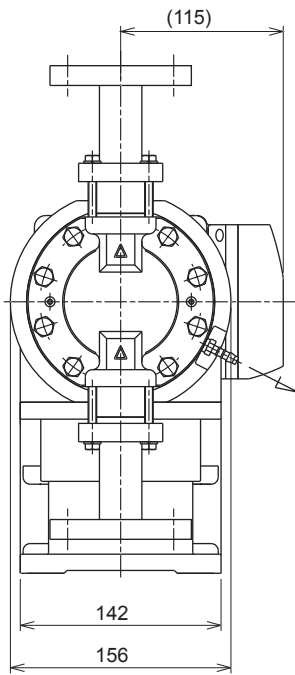

	A	B	C	D	E	F
IX-C150 S6 FA	335	24	—	333.5	—	96.5
IX-C060 S6 FA	270	57	—	339	—	102

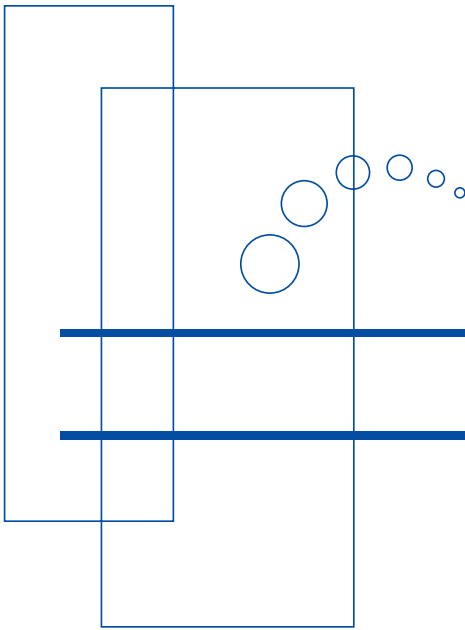

<http://www.iwakipumps.jp>

()Country codes

IWAKI CO.,LTD. 6-6 Kanda-Sudacho 2-chome Chiyoda-ku Tokyo 101-8558 Japan
TEL:(81)3 3254 2935 FAX:3 3252 8892

Australia	IWAKI Pumps Australia Pty. Ltd.	TEL:(61)2 9899 2411	FAX: 29899 2421	Italy	IWAKI Italia S.R.L.	TEL:(39)0444 371115	FAX: 0444 335350
Austria	IWAKI EUROPE GmbH	TEL:(49)2154 9254 0	FAX: 2154 9254 48	Korea	IWAKI Korea Co.,Ltd.	TEL:(82)2 2630 4800	FAX: 2 2630 4801
Belgium	IWAKI Belgium n.v.	TEL:(32)1367 0200	FAX: 1367 2030	Malaysia	IWAKIm Sdn. Bhd.	TEL:(60)3 7803 8807	FAX: 3 7803 4800
China	IWAKI Pumps (Shanghai) Co., Ltd.	TEL:(86)21 6272 7502	FAX: 21 6272 6929	Norway	IWAKI Norge AS	TEL:(47)23 38 49 00	FAX: 23 38 49 01
China	IWAKI Pumps (Guangdong) Co., Ltd.	TEL:(86)750 3866228	FAX: 750 3866278	Singapore	IWAKI Singapore Pte. Ltd.	TEL:(65)6316 2028	FAX: 6316 3221
China	GFTZ IWAKI Engineering & Trading (Guangzhou)	TEL:(86)20 8435 0603	FAX: 20 8435 9181	Spain	IWAKI Iberica Pumps, S.A.	TEL:(34)943 630030	FAX: 943 628799
China	GFTZ IWAKI Engineering & Trading (Beijing)	TEL:(86)10 6442 7713	FAX: 10 6442 7712	Sweden	IWAKI Sverige AB	TEL:(46)8 511 72900	FAX: 8 511 72922
Denmark	IWAKI Nordic A/S	TEL:(45)48 24 2345	FAX: 48 24 2346	Switzerland	IWAKI (Schweiz) AG	TEL:(41)26 674 9300	FAX: 26 674 9302
Finland	IWAKI Suomi Oy	TEL:(358)9 2745810	FAX: 9 2742715	Taiwan	IWAKI Pumps Taiwan Co., Ltd.	TEL:(886)2 8227 6900	FAX: 2 8227 6818
France	IWAKI France S.A.	TEL:(33)1 69 63 33 70	FAX: 1 64 49 92 73	Taiwan	IWAKI Pumps Taiwan (Hsin-chu) Co., Ltd.	TEL:(886)3 573 5797	FAX:(886)3 573 5798
Germany	IWAKI EUROPE GmbH	TEL:(49)2154 9254 0	FAX: 2154 9254 48	Thailand	IWAKI (Thailand) Co., Ltd.	TEL:(66)2 322 2471	FAX: 2 322 2477
Holland	IWAKI EUROPE NL Branch	TEL:(31)547 293 160	FAX: 547 292 332	U.K.	IWAKI Pumps (UK) LTD.	TEL:(44)1743 231363	FAX: 1743 366507
Hong Kong	IWAKI Pumps Co., Ltd.	TEL:(852)2 607 1168	FAX: 2 607 1000	U.S.A.	IWAKI AMERICA Inc.	TEL:(1)508 429 1440	FAX: 508 429 1386
Indonesia	IWAKI Singapore (Indonesia Branch)	TEL:(62)21 690 6606	FAX: 21 690 6612	Vietnam	IWAKI pumps Vietnam Co.,Ltd.	TEL:(84)613 933456	FAX: 613 933399